

Embedded

COMPUTING DESIGN

www.embedded-computing.com

MAY 2005

Volume 3 Number 2

Carrier Grade Linux 3.0: Key Innovations for Worldwide Networks

SPECIAL FEATURE:

Industrial ZigBee security

GUEST FEATURE:

Telematics data integration

PRODUCT GUIDE FEATURE:

VoIP media gateway solutions

EMBEDDED CONSORTIUM:

Service Availability Forum



AdvancedTCA®. We can get you there. Now.

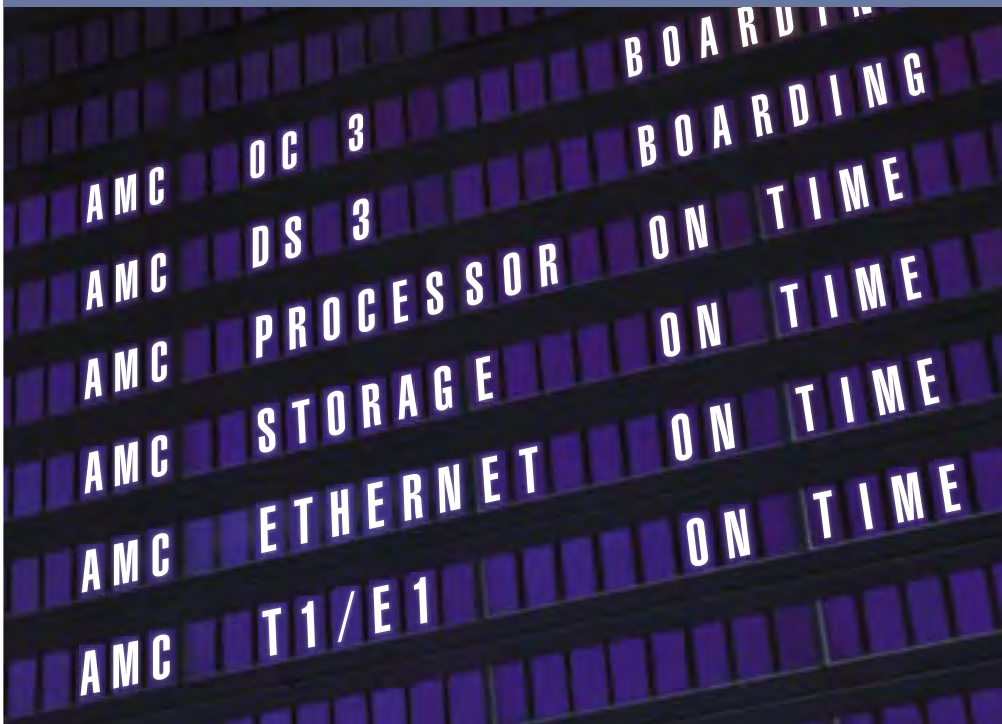

**SBS knows Mezzanines.
PMC or AdvancedMC®, we have the options you need.**

Nobody has more PMCs than SBS, many of them perfect for AdvancedTCA® systems currently in development, and we were the first to deliver Advanced Mezzanine Cards (AdvancedMCs), even before the specification was ratified. Better yet, we have a whole new crop of AdvancedMCs in the wings.

When it comes to PMCs, there's hardly a form of transport we can't offer, everything from Ethernet to OC-3/STM-1, T1/E1, DS3/E3, ATM & Packet—even processors. We also cover Enterprise & Storage with a full range of Fibre Channel, SCSI, iSCSI and Infiniband® HCAs.

Our AdvancedMC roadmap is packed with cards that will allow second generation ATCA systems to achieve their full potential in the scalable, modular future of carrier hardware: ATM, DS3/E3, OC-3, OC-12, T1/E1/J1, Gigabit Ethernet, processors, and the list goes on. No matter where you're going with your system, SBS can get you there.

For the most up-to-date information on our roadmap, visit www.sbs.com/amc.

TELUM 1001-03M



- Full Duplex OC-3 ATM I/O
- Intelligent Platform Management Interface (IPMI).
- Automatic Protection Switching (APS).
- Hot Swap Capable.
- Advanced Mezzanine Card (AMC).

To see our most current AdvancedMC offerings, please stop by booth 55049 at SuperComm in Chicago, June 6-9.

Intel®
Communications
Alliance
Affiliate Member
BRONZE

AdvancedTCA™

SBS
Technologies.

SBS knows. To find out more, visit us at www.sbs.com or call us at 800.SBS.1553

Compact, Reliable Embedded PCs



PC/104 • EPIC • EBC

These "go-anywhere" SBCs can operate where others can't. Rugged, reliable, and built for harsh environments, they provide a PC-compatible architecture that will support Windows®, Linux, RTOS, and software development tools.

Off-the-shelf delivery, knowledgeable tech support, and long-term availability makes our SBCs the right choice for your application.

Call 817-274-7553 or
Visit www.winsystems.com
Ask about our 30-day
product evaluation!

Product	CPU	Size	Onboard	
			Video	Ethernet
EBC-C3	VIA C3	EBX	✓	✓
EPX-C3	VIA C3	EPIC	✓	✓
EBC-BX	Pentium® III	EBX	✓	✓
EBC-LP	Pentium®	EBX	✓	✓
PPM-TX	Pentium®	PC/104-Plus	-	✓
PPM-520	AMD520	PC/104-Plus	-	✓
PCM-520	AMD520	PC/104	-	✓



715 Stadium Drive • Arlington, Texas 76011
Phone 817-274-7553 • FAX 817-548-1358

Embedded

COMPUTING DESIGN

www.embedded-computing.com

VOLUME 3 • NUMBER 3

MAY 2005

COLUMNS

8 Editor's Foreword

Commercial and Industrial Communications
By Mark David Barrera

10 Embedded Perspective

EclipseCon 2005: Embedded emerges from the background
By Don Dingee

14 Eclipse News

The Eclipse Foundation: An open source means to an end
By Mark David Barrera

16 Embedded Europe

Embedded World review and an embedded human body system
By Hermann Strass

19 Embedded Consortiums

Service Availability Forum: Creating open specifications for service availability
By Jon Kenton

24 EEMBC

Performance testing for digital entertainment systems
By Markus Levy

63 New Products

By Chad Lumsden

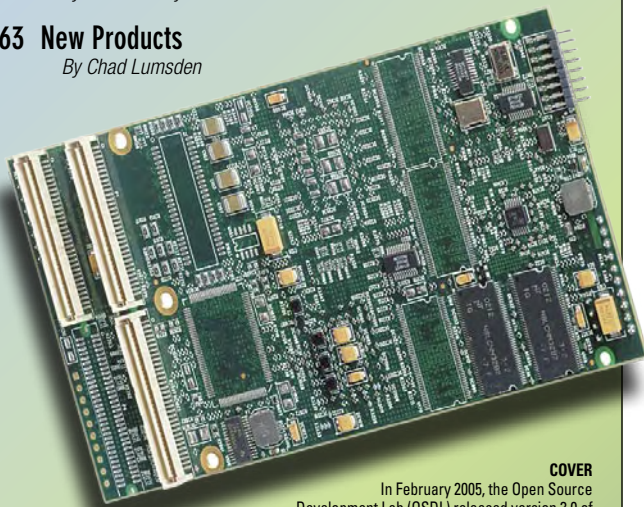

COVER

In February 2005, the Open Source Development Lab (OSDL) released version 3.0 of the Carrier Grade Linux (CGL) Requirements Definition.

PRODUCT

The Performance Technologies MTN4300 media gateway module complies with the PMC format and supports the PICMG 2.15 PTMC option 2 and option 5 standard pinouts.

FEATURES

APPLICATION: Carrier Grade Linux

28 Carrier Grade Linux 3.0 – Building out and looking forward

By Bill Weinberg, OSDL

SPECIAL: Wireless for Industry

35 Industrial-strength security for ZigBee: The case for public-key cryptography

By Mitch Blaser, Certicom

GUEST: Telematics

43 Implementing distributed automotive telematics more efficiently

By Eugene Buechele, ENCIRQ

PRODUCT GUIDE: Communications

53 Building access media gateway solutions with media gateway modules

By Tim Resker, Performance Technologies

57 Product listings: Blades and VoIP

By Chad Lumsden

E-LETTER

May: www.embedded-computing.com/eletter

Fast forward MCU design with the Eclipse IDE

By Yong Cui, Texas Instruments

EVENTS

SUPERCOMM 2005

June 6-9 • Chicago, IL
www.supercomm2005.com

VoIP Developer Conference

August 2-4 • San Francisco, CA
www.tmcnet.com/voipdeveloper

WEB RESOURCES

Subscribe to the magazine or E-letter:

www.opensystems-publishing.com/subscriptions

Industry news:

Read: www.embedded-computing.com/news

Submit: www.opensystems-publishing.com/news/submit

Submit new products:

www.opensystems-publishing.com/vendors/submissions/np

Published by:

 **OpenSystems
Publishing™**

©2005 Embedded Computing Design

4 / May 2005 **Embedded Computing Design**

And you thought SHE was sensitive?

What about your embedded system?

Just like sensing the pea under a mattress, your A/D and D/A system must detect and measure accurately too. So, start your system design with boards that handle real world irritants like temperature, drift and electrical noise.

Sleep easier knowing your measurements are accurate because the effective number of bits for the whole system is close to the ideal 12, 14, 16, or 24-bit resolution of the A/D silicon. Benefit from onboard fault protection circuits that ease system integration by handling the noise and power sequencing challenges common to multi-board designs. Eliminate the need for cumbersome and complicated layers of auto-

calibration software with our low drift specs designed to keep your measurements constant over time.

And our wide selection of cost sensitive A/D and D/A boards is something that will make any princess happy.

We invite you to check out our 12, 14, 16 and 24-bit A/D and D/A single board computers from 12MHz to 533MHz, including VGA, CompactFlash,[®]

Ethernet, GPS, CAN, wireless, and the operating system of your choice.

Call now and let our technical team help smooth out those sensitive issues in your system.



3730 Park Place, Montrose, CA 91020
Voice (818) 244-4600 Fax (818) 244-4246
info@embeddedsys.com

www.embeddedsys.com



24-bit A/D

Our MPC624 provides 24-bit A/D for PC/104 with four channels of instrument grade voltage measurement and/or four channels of direct connect to off-the-shelf sensors.

16-bit A/D, 14-bit D/A

Our headless Pentium,[®] the SBC2596, offers Ethernet, GPS, CAN, DC/DC converter, and CompactFlash on EBX form factor with full 16-bit A/D and 14-bit D/A.

14-bit A/D, 14-bit D/A

Our SBC4495 is a 486/586 EPIC form factor with 14-bit A/D and D/A, VGA/Flat Panel, PCMCIA, wireless, and GPS.

For more fully-featured A/D and D/A SBC boards, visit our web site.



VEHICLE DC-DC FOR ATX / ITX MB, SBC, etc.

Smart Power Supplies designed for use in a
Vehicle/Battery Powered Environment

Features:

Will Not Re-Boot PC During Engine Cranking
Load Dump Protected
Ignition or On/Off Switch Input
Delayed Shut Down Timer
Microprocessor Controlled
Automatic Shutdown @ Low Battery Voltage
ATX / ITX /SBC Motherboard Compatible
Wide input Voltage



Applications:

Law Enforcement/Emergency Vehicles
Non-Emergency Medical Carts
Mobile GPS & Tracking Systems
Mobile MP3 & Multimedia
Computers in Trucks, RV's Boats
Inventory Carts, Dispensing Carts

OPUS
Solutions

www.opussolutions.com
osales@opussolutions.com
Phone: 949-305-4200

RSC #601 @ www.embedded-computing.com/rsc

Embedded COMPUTING DESIGN

AN OPENSYSTEMS PUBLICATION

Embedded and Test & Analysis Group

- Embedded Computing Design
- Embedded Computing Design E-letter
- Embedded Computing Design Product Directory
- Industrial Embedded Systems Product Directory
- PCI Express Product Directory
- PXI Technology Review

Senior Technical Editor Mark David Barrera
mbarrera@opensystems-publishing.com

Technical Editor Chad Lumsden
clumsden@opensystems-publishing.com

European Representative Hermann Strass
hstrass@opensystems-publishing.com

Editorial Director Jerry Gipper

Editorial Director Don Dingee

Special Projects Editor Bob Stasonis

Senior Designer Joann Toth

Senior Web Developer Konrad Witte

Graphic Specialist David Diomede

Circulation/Office Manager Phyllis Thompson
subscriptions@opensystems-publishing.com



OpenSystems Publishing

Editorial/Production office:
13253 La Montana, Ste 207, Fountain Hills, AZ 85268
Tel: 480-967-5581 ■ Fax: 480-837-6466
Website: www.opensystems-publishing.com

Publishers John Black, Michael Hopper, Wayne Kristoff

Vice President Editorial Rosemary Kristoff

Communications Group

Editorial Director Joe Pavlat
Associate Editor (articles) Anne Fisher
Senior Editor (columns) Terri Thorson
Technology Editor Curt Schwaderer
European Representative Hermann Strass

Military & Aerospace Group

Group Editorial Director Chris Ciuffo
Managing Editor Bonnie Crutcher
Assistant Editor Eli Shapiro
Senior Editor (columns) Terri Thorson
European Representative Hermann Strass
European Representative Stefan Baginski

ISSN: Print 1542-6408, Online 1542-6459

Embedded Computing Design is published bi-monthly by OpenSystems Publishing LLC., 30233 Jefferson Ave., St. Clair Shores, MI 48082.

Subscriptions are free to persons interested in the design or promotion of embedded computing systems. For others inside the US and Canada, subscriptions are \$34/year. For 1st class delivery outside the US and Canada, subscriptions are \$60/year (advance payment in US funds required).

Canada: Publication agreement number 40048627
Return address: WDS, Station A, PO Box 54, Windsor, ON N9A 615

POSTMASTER: Send address changes to *Embedded Computing Design*
13253 La Montana, Ste 207, Fountain Hills, AZ 85268

MIL-STD-1553 ARINC-429, 453, 572, 575, 581, 582, 708
ISA
PCI
VME
STD
PC104
MIL-STD-810
CUSTOM BOARDS
Info@bmccorp.com Tel: (516) 997-2118 Fax: (516) 997-2129

SAVE SPACE, TIME & COST

Universal Avionics Digital Interface

BMC

RSC #602 @ www.embedded-computing.com/rsc



Low Profile CompactPCI Platforms Big Performance in Small Places

- » 1U and 2U System Platforms
- » Packaged with the **CPB4612**, CPU Blade based on the Low Power Intel® Pentium® M Processor
- » Processor speeds up to 1.8GHz and with 2MB L2 Cache
- » The board utilizes the Intel® 855GME Chipset with 400MHz FSB and supports dual 10/100/1000 Ethernet
- » DTI's PlexSys Family also includes 4U, 8U, and 12U Systems

>> www.dtims.com

All trademarks and tradenames are the property of their respective owners.



PlexSys-1



CPB4612



PlexSys-2

Diversified Technology's two new additions to the PlexSys Family of CompactPCI Systems are ultra compact enclosures ideal for carriers and service providers deploying communication platforms in mobile environments.



1.800.443.2667 | sales@dtims.com | www.dtims.com

Looking to get more out of your I/O?

Embedded Computer Module Solutions

Diversified Technology's ETX Computer Modules provide a low cost, COTS, CPU solution for numerous industrial, commercial, and military based applications. From ruggedized laptop controllers to industrial control management, embedded boards utilizing DTI's COTS CPU and quick-turn, baseboards designed with your specific I/O features in mind, can provide maximum flexibility while also adding functionality, increased time-to-market capabilities and upgrade ability. Contact DTI today to see how we can help push you ahead of your competition.

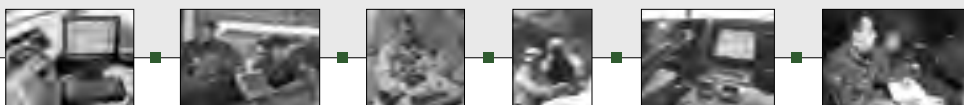

■ Ruggedized Mobile Computing Solutions featuring DTI modules based on the Intel® Pentium® M and Celeron® M Processors



• Intel® Celeron® M Processor based Modules now available!

Key Features

- Highly Integrated Design, Space-Saving Solution
- Reduced Power Consumption
- Low thermal budget
- Improves time-to-market
- Pentium® M design with up to 1GB DDR Memory
- High-End Integrated Graphics
- Full ISA support
- Fully Compliant I²C bus



1.800.443.2667 | sales@dtims.com | www.dtims.com

>> www.dtims.com/etx

All trademarks and tradenames are the property of their respective owners.

Commercial and Industrial Communications



Mark David Barrera

Welcome to the special communications issue of *Embedded Computing Design*. I do not think anyone in the civilized world is communicating quite the same way today as they did a few years ago. We have a wide assortment of articles this issue that cover some of the hottest issues in embedded communications.

Carrier Grade Linux 3.0

■ *Carrier Grade Linux 3.0: Building out and looking forward*, by Bill Weinberg of OSDL. Bill discusses the innovations and enhancements of version 3.0 of the CGL Requirements Definition. This in-depth article by the renowned Linux evangelist is a keeper for anyone involved with CGL.

ZigBee Security for Industry

■ *Industrial-strength security for ZigBee: The case for public-key cryptography*, by Mitch Blaser of Certicom. Mitch discusses the benefits of public-key cryptography in an industrial environment. The benefits include key management, reliability, and system integrity.

Telematics Data Integration

■ *Implementing distributed automotive telematics more efficiently*, by Eugene Buechele of ENCIRQ. Eugene discusses how a data-centric approach to the development of complex systems such as automotive telematics offers a way to streamline the process and improve the system's flexibility.

Media Gateway Solution

■ *Building access media gateway solutions with media gateway modules*, by Tim Resker of Performance Technologies. Tim discusses how the use of a standards-based media gateway module allows media gateway manufacturers to utilize a functionally complete and thoroughly tested media gateway subsystem in the development of their media gateway products.

New Columns

■ *Embedded Perspective*, by Don Dingee and Jerry Gipper. In this new column, the Editorial Directors of the OpenSystems Embedded and Test & Analysis Group will discuss current industry trends and developments. In this issue, Don reviews the well-attended EclipseCon 2005 conference.

■ *Eclipse News*, by myself. It is no secret to anyone who keeps up with the embedded world that everyone has seen the futility of constantly reinventing the wheel. Therein lies the promise of the Eclipse IDE. In my initial column, I give an overview of Eclipse and the Eclipse Foundation.

■ *Embedded Europe*, by Hermann Strass. Hermann will discuss European embedded developments and review European conferences. In this issue, Hermann reviews the Embedded World conference and C-Leg, an amazing leg prosthesis.

As always, I encourage your comments and suggestions concerning this and future issues. Please do not hesitate to send in an article abstract for any complex or controversial subject.

Mark David Barrera
Senior Technical Editor
Embedded and Test & Analysis Group
OpenSystems Publishing

Tri-M SYSTEMS

Hardware Solutions for Embedded Systems

Featuring:

kontron
...always a Jump ahead!

MOPSIcd7

- Intel® ULP Celeron® FANLESS 300 MHz or Intel® LP Pentium® III 700MHz (fan)
- VIA TwisterT chipset
- PC/104+Bus extension (PCI)
- 10/100 MBit Ethernet

Connect Tech Inc.
Industrial Strength Communications

Xtreme/104

- 2, 4, 8 and 12 ports
- Selectable ports for RS-232, RS-422 or RS-485
- Data transfer rates up to 460.8 kbps
- Extended temp and optical isolation models
- Lifetime warranty

M-Systems
Flash Disk Pioneers

Flash Solutions

- DiskOnChip family of products
- Standard interfaces, including 32 pin DIP, USB, and IDE
- Multiple capacities (16MB-1GB)
- Advanced Error Correction

Contact Tri-M Systems for more information:
www.Tri-M.com info@Tri-M.com

1.800.665.5600
Tel: 604.945.9565 Fax: 604.945.9566

Gain Your Freedom Lose the Wires

Wireless Solutions For Embedded Control and Connectivity

Rabbit Semiconductor, the leader in embedded networking, has gone wireless. Network freely without the restraints of cables. Add security with our optional SSL and AES software modules.

Bluetooth® Application and Add-On Kit

The Bluetooth Application Kit includes everything needed to develop a Bluetooth application including RCM3100 RabbitCore, Bluetooth Radio Module, prototyping hardware, and development software. In addition, Bluetooth Add-On Kits provide Bluetooth capability for a number of different RabbitCore models.

Wi-Fi® Application and Add-On Kits

The Wi-Fi Application Kit includes everything required to develop a Wi-Fi Application including RCM3100 RabbitCore, LinkSys Wi-Fi card, prototyping hardware, and development software. The Wi-Fi Add-On Kits provide Wi-Fi capability for a number of different RabbitCore Modules. Both the Application Kit and Add-On Kits allow placement of the Wi-Fi up to 12" from the RabbitCore.

GPRS / M2M Application Kits

These kits provide all of the tools needed to create a GPRS enabled embedded application including a RabbitCore Module, prototyping board, GSM modem, Integrated Development Environment, and royalty-free TCP/IP stack, with sample programs and libraries to simplify development. The M2M kit provides additional tools to facilitate machine-to-machine communication.



Bluetooth
Add-On Kit
\$99

Bluetooth
Application Kit
\$339



Wi-Fi Add-On Kit
\$199

Wi-Fi Application Kit
\$599



Kit Price
\$649

Kit Price
\$699

GPRS / M2M
Application Kits

Free Reference Book With Kit!

Embedded Systems Design using the Rabbit 3000
Microprocessor free with wireless kit purchase.

www.wirelessrabbitkits.com



RABBIT
Semiconductor



2932 Spafford Street, Davis, CA 95616
Tel 530.753.8400



By Don Dingee

EclipseCon 2005: Embedded emerges from the background

Ed. – *The new Embedded Perspective column will be authored by Don Dingee and Jerry Gipper, OpenSystems Publishing Editorial Directors. This month's column ties into another new column for this publication, Eclipse News, which is authored by Mark David Barrera. Refer to that column for detailed information on the Eclipse membership.*

Up and coming

Urs Hoelzle of Google delivered a keynote address on March 2nd at the sold-out second annual EclipseCon 2005 in San Francisco. He remarked that the Eclipse software was “not that easy to find” in the popular search engine, ranking considerably behind the Mitsubishi Eclipse automobile and solar and lunar eclipses. I have noticed since the conference that *eclipse.org*, the website of the Eclipse Foundation, is now the number one result when searching for *eclipse* on Google.

As an embedded developer, you should be noticing Eclipse too. What began as an idea for a Java IDE in 2002 has now broadened into a complete open-source platform for IT and embedded developers. Eclipse offers an open framework for software development that includes a C++ and Java IDE, in addition to web, business intelligence, test, and performance tools. It also supports a number of technology incubator projects including several proposals directly related to embedded technology.

An analogy

One can compare Eclipse to a commercially built house. Eighty percent of the work is standard – foundation, framing, roofing, plumbing, and electrical infrastructure. Unless you happen to be a skilled builder, it would take you a long time to create this from scratch. Most people buy a house and finish the last twenty percent that makes it their home – carpet, appliances, paint, window coverings, lighting, furnishings, and decorations. Over time,

the homeowners remodel and add features to increase value and enjoyment.

Your favorite embedded toolset vendor probably now offers a suite of Eclipse-based tools for code development, testing, debug, and source control that provides eighty percent of your current development needs. With this suite, you can add your twenty percent by selecting the best-of-breed Eclipse plug-ins for your project from a variety of sources. As your requirements change over time, you continue updating your Perspective (the Eclipse term for the view of your environment) by upgrading existing tools and plugging in new ones.

Critical mass

When you combine the Eclipse Strategic Members with the Add-in Providers and Associate Members, it is clear the Eclipse ecosystem is reaching critical mass (refer to the *Eclipse News* column for details).

David Tong, VP of Engineering at Sybase, was asked in the opening press conference how Eclipse is changing the software development landscape. He responded that developers have three common needs:

- rapid development
- best-of-breed tools
- cross-vendor support

Eclipse tools

I hear these needs from embedded developers as well. I talked to a few other people at the conference for a sense of the change that is underway due to Eclipse.

- Accelerated Technology development teams required a line charting function in their Nucleus EDGE toolset based on Eclipse 3.0. They were able to locate an Eclipse charting plug-in on the Internet, download and integrate it in about a half a day.
- SlickEdit has released an enhanced version of their multi-language code editor as an Eclipse 3.0 plug-in, allowing it to be the editor of choice for many Eclipse-based environments.
- Catalyst Systems has released a new version of their automatic build generator, OpenMake, as an Eclipse 3.0 plug-in. This relieves the tedium for configuration managers of building and maintaining make files by hand while still allowing developers to get under the hood and control the build process.
- A team from the Los Alamos National Laboratory has submitted a proposal for FORTRAN support under the Eclipse Parallel Tools Project. After the technical session on C Development Tools, attendees from Los Alamos, NASA, other government labs, and Intel discussed the possibilities for working with FORTRAN tools in the same manner as they work with C++ and Java.

Low cost drives new opportunities

Tim O'Reilly of O'Reilly Associates remarked that “starting a software business today is less expensive than it ever has been, since open source can be leveraged.” He observed that innovative new ideas can be built quickly and inexpensively upon a stable and widely available open-source base.

Eclipse is starting to benefit embedded application developers, with projects such as the embedded Rich Client Platform proposal, and the Electronic Healthcare Record proposal.

THE BEST-PERFORMING

ANALOG I/O PC/104 BOARD...



**Automatic
Autocalibration
— only from
Diamond Systems!**

US Patent No. 6,281,818



...JUST GOT BETTER!

INTRODUCING THE NEW DMM-32X-AT ANALOG I/O PC/104 BOARD

Introducing the new DMM-32X-AT analog I/O PC/104 board with *automatic autocalibration* from Diamond Systems. Using our patented technology (US Pat. 6,281,818), the DMM-32X-AT is so smart, it knows when to calibrate itself. All calibration circuitry and control logic are built right in, so the DMM-32X-AT can calibrate itself whenever it needs to, without any user intervention whatsoever!

NO PROGRAMMING. NO SETUP. NO WORRIES!

You don't have to do anything at all – the DMM-32X-AT takes care of everything all on its own. Regardless of changes in ambient temperature or the passage of time, or even your operating system or programming language, you're guaranteed accurate analog measurements over the life of the product.

The Benefits of Autocalibration

While other PC/104 A/D boards claim to operate at extended temperature, the fact is, if your board doesn't have autocalibrating technology, you could be receiving inaccurate measurements, putting your entire system or mission at risk. Autocalibration Technology from Diamond Systems provides up to 10x reduction in measurement errors over competitors' non-autocalibrating boards. *And only Automatic Autocalibration from Diamond Systems does it all without any user programming or effort required.*

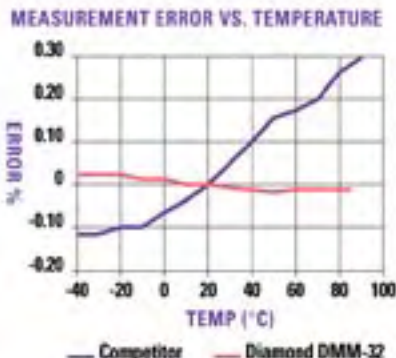

On top of it all, the DMM-32X-AT is **100% backward compatible** with our industry-leading DMM-32-AT board, already used around the world in industrial, military, aerospace, medical, and scientific applications. All your software, cabling, and system integration efforts are protected – the DMM-32X-AT acts as a drop-in replacement, providing an instant upgrade for improved performance.

Want even more? How about this: The DMM-32X-AT has a built-in RS-232/485 serial port and on-board microcontroller for remote communications and control, so it can be used standalone – **No CPU Required!**

And as usual, DMM-32X-AT is fully supported by our free Universal Driver software for Linux, RTLinuxPro, QNX, VxWorks, Windows 98/2000/XP/XPe/CE.NET, and DOS.

The world leader in PC/104 analog I/O does it again.
Automatic Autocalibration — only from Diamond Systems!

DMM-32X-AT SPECIFICATIONS AT A GLANCE

ANALOG INPUTS	32 single-ended / 16 differential, 16-bit resolution
MAX SAMPLING RATE	250KHz
ON-BOARD FIFO	1,024 samples
INPUT RANGES	9, programmable, ±10V down to 0-1.25V
ANALOG OUTPUTS	4, 12-bit resolution
MAX OUTPUT RATE	100KHz with on-board 1,024 sample waveform buffer
DIGITAL I/O	24, programmable direction
AUTOCALIBRATION	Automatic, both A/D and D/A; User-configurable trigger setpoints
OPERATING TEMP	-40 to +85°C

Visit www.diamondsystems.com/products/dmm32x

DIAMOND SYSTEMS CORPORATION

8430-D CENTRAL AVENUE
NEWARK, CA 94560

TEL: (510) 456-7800 www.diamondsystems.com

RSC #11 @ www.embedded-computing.com/rsc

THINKING PC/104? THINK DIAMOND.

► Performance Beyond Limits

... ready for Extreme Embedded Computing?



ETXexpress-PM

- Highest performance state of the art embedded module
- Intel® Pentium® M processor and advanced Intel® chipset

ETXexpress products are next generation embedded modules based on the PICMG COM Express standard. ETXexpress provides the highest performance and I/O bandwidth available in COMs.

- PCI Express - the elemental data path
- Gigabit Ethernet - for high connectivity
- USB 2.0 - for fast periphery
- Serial ATA - for fast drives
- ACPI - for optimized power management

Get ready. Get ETXexpress
Visit www.kontron.com/ETXexpress



kontron
... always a Jump ahead!

www.kontron.com
sales@us.kontron.com

Kontron and the Kontron logo are registered trademarks of Kontron Embedded Computers AG. All other trademarks are the property of their respective owners. ©2005 Kontron America, Inc.

eRCP proposal

The embedded Rich Client Platform (eRCP) builds on the work already performed on the desktop RCP, and targets an open user interface for mobile phones and PDAs. The challenge is to reduce the RCP footprint and enhance performance, while retaining the upward compatibility of the interface and applications to the desktop.

IBM, Motorola, and Nokia are contributing to the effort, with Sony Ericsson and France Telecom indicating interest and providing feedback. eRCP may have a broad impact on additional embedded devices as it builds momentum.

Healthcare proposal

The vertical healthcare market has an aggressive vision for an Electronic Healthcare Record (EHR) created around standards from the Object Management Group (OMG) and Health Level 7.

It targets the integration of health records across handheld devices, diagnostic instruments, and back-end IT systems. Mike Milinkovich, Executive Director of the Eclipse Foundation, stated a strong EHR implementation could save "hundreds of billions of dollars" in annual US healthcare costs.

ESC San Francisco 2005

Eclipse also had a presence at the latest Embedded Systems Conference:

- Eclipse booth – The following Eclipse members have formed the Embedded Marketing Working Group, and presented their products at a special booth at the conference: Accelerated Technology, Enea, QNX, Real-Time Innovations, SlickEdit, Telelogic, TimeSys, and Wind River. The group is co-chaired by Robert Day of Accelerated Technology, and Martin Klaus of Wind River.
- Membership Upgrade – Wind River elevated their status to Eclipse Strategic Developer, and will lead a new Device Software Development Platform project.

An evolution

The world of Eclipse is evolving rapidly, and a great deal of updated information is available at the Eclipse Foundation website (eclipse.org). For an excellent overview of Eclipse, refer to the article by Robert Day of Accelerated Technology in the January 2005 issue of *Embedded Computing Design*.

We will be watching together as Eclipse continues to develop, and I would like to hear what you think about Eclipse and how it has changed your development efforts. Please drop me a line, especially concerning the following:

- Have you noticed Eclipse?
- Are you using an Eclipse-based framework for embedded development?
- Are you contributing code back to Eclipse?

For more information, e-mail Don at: dgingee@opensystems-publishing.com



ANALOG I/O DIGITAL I/O SERIAL I/O FPGA COUNTER/TIMER QUADRATURE

Industry Pack I/O Modules

If you need a variety of I/O functions or have a slew of signals to process, then Acromag Industry Packs are your solution. Plug in assorted I/O modules on a carrier card and you can replace several boards with one. Or, insert multiple IPs of the same type for a single-slot solution with tremendous capacity. Now that's flexibility.

Acromag offers the widest selection. Our Industry Pack modules and carrier cards all come with an unbeatable combination of features, performance, and value.

- Choose from more than 100 IP modules
- Carriers for 3U/6U VME, CompactPCI, PCI
- Software drivers for RTOS and Windows™

Flexibility means options. And Acromag has more embedded I/O options than anyone.

For flexible, capable, and reliable I/O solutions, think Acromag.



www.acromag.com

800-881-0268 or 248-624-1541

RSC #1302 @ www.embedded-computing.com/rsc

Now Available



2nd Annual
Resource Guide

www.compactpci-systems.com

Security Protocols for Embedded Systems



Cryptographically secure, FIPS validated, Denial-of-Service resistant security software for VxWorks and Linux



(510) 505-98F1 ext 5
Sales@TeamF1.com
www.TeamF1.com

RSC #1301 @ www.embedded-computing.com/rsc

The Eclipse Foundation: An open source means to an end

As the editor of *Embedded Computing Design*, I have received many requests for articles on the Eclipse development system. After reviewing the requests along with ESC San Francisco and EclipseCon 2005 wrap-ups, it is readily apparent that there is more than enough interest in the embedded community to justify the establishment of an Eclipse News column.

I will author this column with the assistance of the Eclipse Foundation and the Eclipse community at large. As a show of support for Eclipse, OpenSystems Publishing has joined the foundation as an Associate member.

For this initial column, here is a quick overview of Eclipse and its governing body. I included a snapshot of the members in this issue to point out to those devoted to proprietary solutions to review the tables carefully, as your competitors may be listed.



By Mark David Barrera

What is Eclipse?

For a detailed summary of Eclipse, refer to the article entitled "Eclipse: The development system that crosses RTOS boundaries" in the January 2005 issue of *Embedded Computing Design*. This article by Robert Day of Accelerated Technology will prove to be of special interest to those completely unfamiliar with Eclipse. It is available on our website at the following address: www.embedded-computing.com/articles/id/?190

Here are some key points from that article:

- **Open platform** – Eclipse is an open platform for tool integration built by an open community of tool providers. To quote the Eclipse website: "The Eclipse Platform is an open IDE for anything, and for nothing in particular."
- **Open community** – Eclipse is an open source community whose projects are focused on providing an extensible development platform and application frameworks for building software.
- **Eclipse plug-ins** – Each tool provider can build their tools to a certain set of rules and APIs that allow them to plug in to the Eclipse framework. If the Eclipse plug-in rules are adhered to, the embedded tools will track the latest versions of the Eclipse framework, as well as plug into other Eclipse-based environments.
- **Licensing** – The Eclipse Public License (EPL) provides royalty-free source code and world distribution rights, and allows tools developers to offer the Eclipse framework and their plug-in products without putting their own Intellectual Property (IP) back into the community.

The Eclipse Foundation

There are five classes of membership, and current members (April 2005) are listed in Table 1. Note that the Committer members are not listed as they are in a constant state of flux. The following member class descriptions are from the *Eclipse Foundation Membership Agreement* that is available at the Eclipse website.

Strategic Developers

Strategic Developer members agree to lead an Eclipse Platform development project and commit, on a full time basis, a Developer who shall act as leader for this project, and a minimum of seven additional Developers assigned to work on this project or other Eclipse Platform development projects. Strategic Developers are entitled to Board representation and are permitted to vote with the Membership At-Large. The Strategic Developer membership fee varies according to the member's annual revenue.

Strategic Consumers

Strategic Consumer members agree to commit, on a full time basis, up to two Developers to participate in an Eclipse Platform development project. The total commitment is tied to the member's annual membership fee level. Strategic Consumers are entitled to Board representation and are permitted to vote with the Membership At-Large. The Strategic Consumer membership fee varies according to the member's annual revenue and/or staffing commitment.

Add-in Providers

Add-in Provider members are entitled to Board representation and are permitted to vote with the Membership At-Large. Add-in Providers pay a \$5,000 membership fee.

Committers

Committer members are individuals that are involved in the development of the Eclipse Platform and do not fall within any other membership class. Committers are entitled to Board representation and are permitted to vote with the Membership At-Large. Committers do not pay a membership fee.

Associates

Associate members are entities such as standards organizations, research institutions, academic institutions, open source organizations, publishing organizations, and other organization types as established from time to time by the Eclipse Foundation Board of Directors. Associates are not represented on the Board of Directors and are not permitted to vote with the Membership At-Large. Associates do not pay a membership fee.

Board of Directors

The members of the Board of Directors are selected according to the above criteria, and are listed in Table 2.

Future columns

I am open to any suggestions from the Eclipse community for future *Eclipse News* columns. You can send your abstracts to: mbarrera@opensystems-publishing.com

For more information on Eclipse:

Eclipse Foundation, Inc.

102 Centrepointe Drive

Ottawa, Ontario • Canada K2G 6B1

Tel: 613-224-9461 • Fax: 613-224-5172

E-mail: info@eclipse.org

Website: www.eclipse.org



PMC I/O Modules

Looking for higher performance without sacrificing the flexibility of a mezzanine format? Acromag PMCs enable faster data transfer rates with all the benefits of a PCI interface.

Acromag's wide variety of I/O modules includes high-speed A/D, high-resolution D/A, high-density digital I/O, and even extended temperature ranges. Now *that's* capability.

New FPGA I/O means greater capability. Re-configurable FPGAs let you design custom I/O boards much faster and at a fraction of the cost. Download your unique code into the FPGA for unlimited signal processing possibilities.

- Virtex-II[®] FPGA with up to 3 million gates
- 1MB on-chip RAM, 9MB on-board SRAM
- Variety of analog & digital I/O configurations

For flexible, capable, and reliable I/O boards, think Acromag.

Acromag 
THE LEADER IN INDUSTRIAL I/O

www.acromag.com

800-881-0268 or 248-624-1541

RSC #15 @ www.embedded-computing.com/rsc

Actuate	Strategic Developer
Accelerated Technology	Add-in Provider
ACM Queue magazine	Associate
Acucorp	Add-in Provider
Addison Wesley	Associate
Advanced Systems Concepts	Add-in Provider
Agitar Software	Add-in Provider
Aldon	Add-in Provider
Aonix	Add-in Provider
AvantSoft	Add-in Provider
BEA Systems	Strategic Developer
Borland Software	Strategic Developer
BZ Media	Associate
Catalyst Systems Corporation	Add-in Provider
CollabNet	Add-in Provider
Comm. and Media Arts (CMA)	Associate
Computer Associates	Add-in Provider
Compuware	Add-in Provider
Discovery Machine	Add-in Provider
Eclipse Plug-In Central (EPIC)	Associate
Embarcadero Technologies	Add-in Provider
ENEA	Add-in Provider
Ericsson	Add-in Provider
ETRI	Add-in Provider
Exadel	Add-in Provider
Fraunhofer Institute (FOKUS)	Associate
Fujitsu Limited	Add-in Provider
Genuitec LLC	Add-in Provider
Hitachi Software Division	Add-in Provider
Hewlett-Packard	Strategic Consumer
IBM	Strategic Developer
ILOG	Add-in Provider
INNOOPRACT	Add-in Provider
Inpriva	Add-in Provider
Instantiations	Add-in Provider
Intel	Strategic Developer
ITG	Add-in Provider
JBoss	Add-in Provider
Kinzan	Add-in Provider
Klocwork	Add-in Provider
Logic Library	Add-in Provider
Lombardi Software	Add-in Provider
M1 Global Solutions	Add-in Provider
M7 Corporation	Add-in Provider
Mercury Interactive	Add-in Provider

Meta-1 GmbH	Add-in Provider
Micro Focus	Add-in Provider
MKS	Add-in Provider
MontaVista	Strategic Consumer
Motorola	Add-in Provider
mValent	Add-in Provider
Novell	Add-in Provider
NTT Comware	Add-in Provider
Object Management Group (OMG)	Associate
ObjectWeb	Associate
OC Systems	Add-in Provider
Omondo	Add-in Provider
OpenSystems Publishing	Associate
Optena Corporation	Add-in Provider
Oracle	Add-in Provider
PalmSource	Add-in Provider
Panscopic	Add-in Provider
Parasoft Corporation	Add-in Provider
Penton Technology Media	Associate
PureEdge	Add-in Provider
QNX Software	Add-in Provider
Real-Time Innovations	Add-in Provider
Red Hat	Add-in Provider
RTC Group	Associate
SAP	Strategic Consumer
SAS	Add-in Provider
Scapa	Strategic Developer
Secure Software	Add-in Provider
Serena	Strategic Consumer
SlickEdit	Add-in Provider
SocialPhysics.org	Associate
Soft Landing Systems	Add-in Provider
Sybase	Add-in Provider
Teamstudio	Add-in Provider
Telelogic	Add-in Provider
Tensilica	Add-in Provider
Texas Instruments	Add-in Provider
THALES	Add-in Provider
TimeSys	Add-in Provider
Tsinghua University	Associate
Unisys	Add-in Provider
VA Software	Add-in Provider
Wasabi Systems	Add-in Provider
webMethods	Add-in Provider
Wind River	Strategic Developer

Table 1

Michael Bechauf, SAP AG Strategic Consumer	Robert Levy, Computer Associates Add-in Provider	Jim Ready, MontaVista Strategic Consumer
Ed Cobb, BEA Strategic Developer	Howard H. Lewis, SlickEdit and Discovery Machine Add-in Providers	Raaj Shinde, Borland Strategic Developer
Mark Coggins, Actuate Strategic Developer	Scott Lewis Committer	Dave Thomson, IBM Strategic Developer
Tomas Evensen, Wind River Add-in Provider	Kai-Uwe Maetzel Committer	David Tong, Sybase Add-in Provider
Boris Kapitanski, Serena Strategic Consumer	Rich Main, SAS Add-in Provider	John Wiegand Committer
Jonathan Khazam, Intel Strategic Developer	Michael Norman, Scapa Strategic Developer	Todd Williams, Genuitec LLC Add-in Provider
	Michael J. Rank, Hewlett-Packard Strategic Consumer	

Table 2



Embedded World review and an embedded human body system



By Hermann Strass

Embedded World review Nuernberg, Germany • February 22–24

Despite unusually large amounts of snowfall and the resulting traffic difficulties, about 11,000 visitors made their way to Nuernberg for this exhibition and conference.

Conference attendance increased by 25 percent and the number of exhibitors increased by 22 percent with more than one-third of the exhibitors coming from foreign countries (with most from the USA). About 480 companies exhibited their products in about 112,000 square feet of space in three exhibition halls. Each hall had a different focus (software, hardware, and tools).

Embedded World in Nuernberg was roughly the same size and had a similar number of attendees as Embedded Systems in San Francisco, USA. However, there were more exhibitors (especially international exhibitors) in Nuernberg.

Embedded awards and keynotes

The *embedded Award 2005* was presented to one outstanding company/product in each of three categories:

- Contec (Austria) received their award for a very complex and extremely efficient phase control loop.
- aicas (Germany) was awarded for their real-time, Java-based software for aerospace and transportation applications.
- Lauterbach Datentechnik (Germany), known for their TRACE development tools, have developed a novel cache analyzer which can determine and fine-tune cache usage dynamically in memory constrained real time embedded systems.

Keynote addresses were held by internationally known experts from Texas Instruments, QNX, I-Logix, ENEA, and the Realtime Linux Foundation.

Experience Area Automotive

The conference included an *Experience Area Automotive* section, as automotive

embedded electronics is an extremely important and booming market sector with double-digit growth rates in certain areas, such as Germany. Modern automobiles may include anywhere from 40 to 80 industrial-grade microprocessors in addition to several serial busses.

Most of the devices in these automotive applications are not normal commercial production devices due to harsh environmental and safety requirements. Companies like Infineon (Germany), ELMOS (Germany), Freescale (USA), and others produce automotive devices for these demanding applications. European automobile manufacturers are reducing the amount of gimmicks (unnecessary functions) and adding more and better quality safety and driving comfort functions.

One interesting function is available on BMW 7-series automobiles. As you drive by a parking spot on the side of the road, electronics measure the size of the spot to see if the car will fit into it for parking. The driver then just switches into reverse gear and the car automatically parks without any further assistance from the driver.

Infineon reported that about 33 percent of all worldwide automotive engine-control microprocessors are made by their company. Some of these microprocessors sell for less than one dollar in 10K quantities. They estimate that on average there are about 20 chips from Infineon in any new passenger car.

SBS partners with VSYSTEMS and Data Respons

SBS Technologies Europe (Germany) announced partnerships with VSYSTEMS (Norway) which is a sales subsidiary of VMETRO (Norway), and with Data Respons (Norway) in the European market at Embedded World. SBS and VMETRO are very well known in the bus and board world in Europe and North America. Data Respons, established in 1986, is an embedded solutions company in Norway with subsidiaries in all Scandinavian countries.

Data Respons has recently opened a subsidiary in Germany as a base in Europe's largest embedded market (40 percent). Kenneth Ragnvaldsen, CEO of Data Respons, said they have set out "to become the leading 'Embedded Solutions Company' in Europe by the year 2010." Data Respons have shown an impressive growth rate as their 2004 Nordic market operating revenues were over 34 percent higher than in 2003. Data Respons follows a concept of solutions (complete), services (analysis, planning, development, consulting), and products (COTS, embedded) to build recurring business in the embedded market segment.

Embedded human body system

Embedded systems are not always embedded in technical equipment. An artificial leg itself is technical, but it becomes an embedded body system when it is attached to the human body and operates in unison with the biological leg. The C-Leg (computerized leg) from Otto Bock Healthcare (Germany) is the world's first completely microprocessor-controlled dynamic walking system with hydraulic swing and stance phase control (Figure 1).



Figure 1

The C-Leg embedded system was jointly developed over a seven-year time-period by the Austrian subsidiary and innovation center of Otto Bock Healthcare in Vienna, and by the medical research department of the Technical University in Berlin, Germany.

C-Leg operation

It functions like part of a humanoid robot as described in *VMEbus Systems* magazine (February 2005, pg. 18). However, the C-Leg, as an integral part of a human body, needs more elaborate dynamic control to walk in synchronism with the other leg and to offer smooth walking capabilities to avoid damage and fatigue for the rest of the body. The embedded system is based on scientific gait analysis and biomechanical studies. It automatically adapts stance stability on heel contact to avoid unintentional bending of the knee.

All this is performed under microprocessor and software control based on inputs from numerous sensors, by controlling electrical and hydraulic movement and damping systems dynamically in realtime. Otto Bock Healthcare has designed software that predicts the necessary force and resistance to move through different phases of the gait cycle, and it includes precautions against stumbling. It can be adjusted to the individual person's weight and gait by temporal connection to a notebook computer to download individually fine-tuned bionic software routines.

In normal use, the sensors monitor the person's movement 50 times per second, and automatically adjust for changes in terrain including changes for rough ground. In addition, knee stability when standing and various walking speeds are automated in the embedded control program. Since there are no artificial muscles, gravity and inertia are also used to facilitate walking as natural as possible.

C-Leg advantages

The C-Leg provides several benefits over purely mechanical knee systems. The amputee can ambulate at greater speeds with optimal biomechanically correct symmetry while expending less energy. Most importantly, they can walk safely step-over-step up and down stairs. The built-in battery lasts anywhere from 25 to 40 hours so it can support a full day's activity. The recharge can be performed overnight or while traveling in a car via a cigarette lighter adapter.

The C-Leg was certified by the FDA for use by above-the-knee amputees after

passing the world's most severe tests. It is approved for persons weighing up to 125 kg (275 lbs). A number of insurance companies reimburse the cost of a C-Leg. The C-Leg comes with a 3-year worldwide mobility guarantee (with 2-year extension possible) and a free once-a-year check-up. A temporary service C-Leg is available free of charge if needed.

C-Leg users

During the first six years on the market, 7000 C-Legs were fitted worldwide with half of them fitted in the USA. For example:

- US Army SFC Michael McNaughton stepped on a land mine while stationed at Bagram Air Base in Afghanistan. He has returned to active military duty after a C-Leg prosthesis was fitted by the Walter Reed Medical Center in Washington, DC (Figure 2).



Figure 2

- Curtis Grimsley, a former basketball player and track-and-field athlete fitted with a C-Leg prosthesis, escaped the September 11, 2001 collapse of the World Trade Center towers by making his way down 70 stories from his office to safety in a nearby business building.

C-Leg is a registered trademark of the Otto Bock Healthcare in the United States and other countries. Other company product and service names may be the trademarks or service marks of others.

Hermann Strass is an analyst and consultant for new technologies, including industrial automation, computer bus architectures, mass storage technologies, and industrial networking. He is the author of several books and trade magazine articles, and an active member of several international standardization committees.

For more information, e-mail Hermann at: hstrass@opensystems-publishing.com

Reliability.

ANALOG I/O DIGITAL I/O SERIAL I/O FPGA COUNTER/TIMER QUADRATURE

PCI and CompactPCI® I/O

Designed for industrial and military applications, Acromag PCI and cPCI I/O boards deliver dependable operation in hostile environments.

COTS-grade components provide superior performance, and our extended temperature models will withstand -25 to 85°C ranges. Now that's reliability.

Reliability also means long-term availability.

Acromag boards are designed for a life span of at least 10 years. Our lifecycle management program ensures that your system designs will be sustainable long into the future.

- Wide variety of long/short PCI, 3U/6U cPCI
- High-performance and high-density
- Software support for RTOS and Windows®

For flexible, capable, and reliable I/O solutions, think Acromag.



www.acromag.com

800-881-0268 or 248-624-1541

RSC #17 @ www.embedded-computing.com/rsc

WHAT MAKES A PRODUCT EXTINCT?



EBX



PC/104



EPIC



STD 32

Your OEM product can become extinct long before its time, unless you have a long-term commitment from your SBC vendor. VersaLogic guarantees product availability for at least five years from its introduction date.¹ That saves you from tossing future sales into the jaws of competitors because you suddenly cannot get your hands on the boards you need, when you need them. **VersaLogic's Extended Life-Cycle Policy is just one of the services that helped us earn the prestigious VDC Platinum Vendor award.** From our close ties with key vendors to our pre-design component studies, we make it our business to extend your product's life. So sink your teeth into the details at www.VersaLogic.com/pv12. Start a long, long-term relationship by calling us at (800) 824-3163.



Before Kristin Kuros joined VersaLogic's sales support team, she guided tours at a natural history museum. She really knows how to keep products off the endangered species list.



Platinum Vendor award by
Venture Development Corporation
2002 and 2003



(800) 824-3163
www.VersaLogic.com/pv12



By Jon Kenton

Service Availability Forum: Creating open specifications for service availability



Whether in business or our personal lives, we are dependent on technology now more than ever. That dependence goes far beyond the personal devices we use directly such as laptops, and into the infrastructure that supports those devices.

Round-the-clock service availability is now obligatory. It is the goal of the Service Availability Forum to foster the integration of COTS solutions into high availability networks.

Availability requirements

In such an environment, *dependence* and availability go hand in hand. Based on the literal definition, *dependence* equates to a need for something or somebody to be available in order to exist or survive. Thus, availability (defined as the condition of being available) is the fundamental requirement to fulfill the needs of dependence.

Reliability used to be a key metric of performance. Availability goes beyond how reliable something may be and is a measure of a system or services readiness to perform its function when it is needed, no matter its level of reliability. As we know, reliability in real life situations cannot be 100 percent, therefore highly available systems must account for less than perfect reliability using advanced methodologies, technologies, and architectures.

Availability and telecoms

Telecommunication companies have been using service availability metrics for many years to quantify their equipment's capability.

5-nines (99.999 percent) availability is the minimum standard for the majority of networks. Service availability for 99.999 percent of the time in a 24/7 environment equates to approximately 5 minutes of downtime per year. Downtime includes any time out of service whether it is planned or unplanned.

6-nines (99.9999 percent) availability is now required, and these systems begin to approach 100 percent availability as the allowed downtime is a mere 32 seconds a year!

Proprietary solutions

Such levels of availability have been achievable only through the use of highly proprietary and customized architectures and product features, developed to meet the needs of the individual equipment provider and application requirements. Such development and customization is costly and takes a large staff to maintain.

The SA Forum

Standardization of these architectures to make COTS products will reduce this burden making it easier for applications of all types to meet stringent availability models. The Service Availability Forum (SA Forum) is driving this standardization effort to help enable a new open world for service availability.

The SA Forum is a standards body comprised of industry-leading communications and computing companies. Together these companies support and participate in numerous working groups to develop and publish high availability and management software interface specifications. The SA Forum then works to promote these specifications and facilitate their adoption by the industry as a whole.

The SA Forum mission is to "foster an ecosystem that enables the use of commercial off-the-shelf building blocks in the creation of high availability network infrastructure products, systems, and services."

SA Forum membership

SA Forum members vary from small software companies to telecommunication giants (Table 1). Members represent the future providers and users of service availability solutions based on the specifications developed by the forum. Membership information is available at the SA Forum website (saforum.org).

Artesyn Technologies	IBM	Oracle Corporation
Augmentix Corporation	Intel	Pigeon Point Systems
Clovis Solutions	Kontron	Phoenix Technologies
Continuous Computing	Lucent Technologies	Radisys
Ericsson	MontaVista Software	Siemens AG
Fujitsu Limited	Motorola	Solid Information Technology
Fujitsu Siemens Computers	MySQL AB	Sun Microsystems
GNP	NEC	TietoEnator
GoAhead Software	Nokia	UXComm
Hewlett-Packard	Nortel Networks	Veritas Software
Huawei	NTT	Wind River Systems

Table 1

SA Forum benefits

All of the companies who are committing resources to this effort recognize the benefits for themselves and the industry as a whole. The SA Forum clearly defines the benefits of adoption at multiple levels from technology creation to service delivery.

Network Service Provider/Operator benefits:

- Faster time to market and revenue
- Simplified deployment of new products
- Accelerated innovation
- Choice of equipment providers
- Lifecycle cost reduction

Network Equipment Provider benefits:

- Increased focus on system definition, integration, and value-add
- Faster time to market/revenue
- Broader choice of technology provider, pick from best in breed
- Product lifecycle cost reduction

Hardware and Software Vendor benefits:

- Larger standard product market
- Reduced need for product customization
- Simplified ecosystems for partnering and solution integration

SA Forum specifications

Application Interface Specification

The first of the three primary SA Forum specifications is the Application Interface Specification (AIS). This specification defines the interface between the applications and the High Availability (HA) middleware.

Compliant applications remain independent of the underlying platform by using the features of the AIS. This greatly enhances portability and enables a very robust HA stack management structure.

The fundamental concept on which AIS builds is that of clustering. By taking advantage of redundant hardware and software components, the AIS interface is able to increase service availability by masking the four possible failure zones:

- application
- middleware
- operating system
- hardware

The AIS itself is a C language API that provides a number of services to manage a distributed mechanism for supporting cluster membership, application failover, and checkpointing. Through the creation of multiple nodes (even within a single system) service availability is improved by distributing the application and middleware across the logical and/or physical nodes.

Hardware Platform Interface specification

The Hardware Platform Interface (HPI) specification defines the interface between the hardware and the HA middleware and makes each independent of the other (Figure 1).

As with the AIS, the HPI enables portability and it therefore promotes platform vendor independence. It also means that an application can

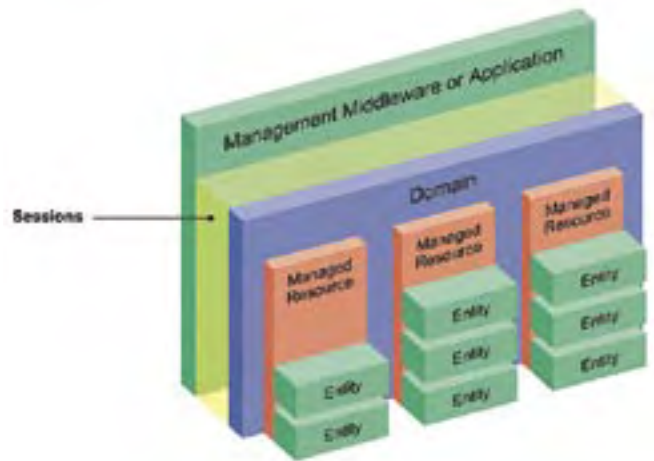

Figure 1

be created that can span multiple hardware architectures while remaining compatible from a management perspective. Every hardware platform has similar elements, although they can differ significantly in implementation.

The HPI creates an abstracted view of the platform hardware-specific characteristics of a system and provides a standardized methodology for monitoring and control. The abstracted view is divided into *entities*. Each entity has associated controls, sensors, entity inventory repositories, and watchdog timers. These elements provide the HPI with the means to manage the overall state and health of the underlying hardware platform.

Systems Management Specification

The Systems Management Specification (SMS) is the newest of the specifications developed by the SA Forum and will be released later in 2005. The SMS defines the interfaces to access the monitoring and control aspects of the AIS and the HPI interfaces, as well as a comprehensive notification interface for HA systems.

The overall goal of the SMS is to address the administrative operations and management of cluster configuration, platform system model configuration, deployment, and statistical data monitoring.

Specification relationship

The relationship of the three specifications is shown in Figure 2. The figure depicts how the specifications will work together in a layered architecture that builds from the hardware platform at the foundation, to the end application at the top of the stack.

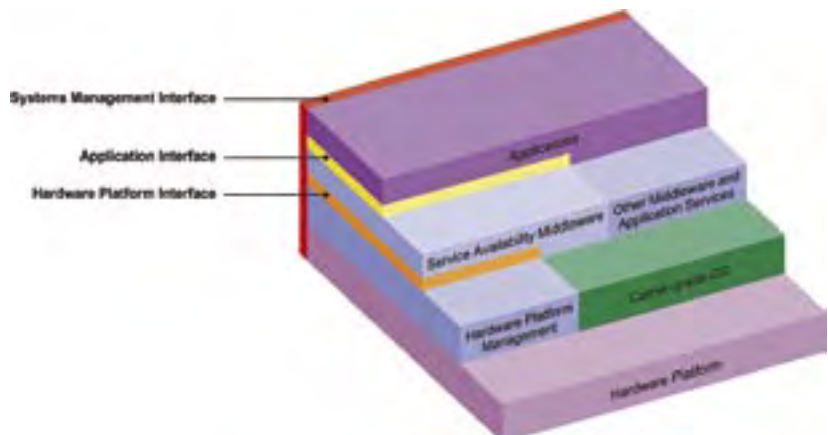

Figure 2

SA Forum resources

There are a number of resources available at the SA Forum website.

Specifications

- Hardware Platform Interface (HPI) specification: The full specification and header files are available.
- Application Interface Specification (AIS): The full specification and header files are available.
- Systems Management Specification (SMS): The interface specification that enables the service event and error reporting for AIS and HPI. The SMS will be available for download in mid-2005.

Product registry

The registry is a program that enables members to post their implementation methodology to the SAF Product Registry for evaluation and testing. Compliance with all registration requirements enables members to label their products as *Service Availability Forum Registered*.

As more offerings become available from the community, the registry will act as a guide for users and adopters of SA Forum compliant products to help select those that best match their specific requirements.

“...ensuring adherence and compliance to the specifications is crucial to the goals of portability and compatibility.”

HPI Developer Forum

This online facility allows developers to submit inquiries to the HPI Developers Forum. The idea is to obtain feedback on implementation issues from others who have already been through the process.

Publications

The SA Forum website provides access to various documents and white papers including:

- The Service Availability Forum Platform Interface
- Implementing HA databases within an SA Forum AIS-compliant Framework
- SA Forum datasheet. Provides a brief overview of the goals, objectives, and deliverables of the Forum.

SA Forum working groups

The SA Forum is driven by the Technical, Marketing, and Compliance workgroups. It is within these three primary groups that the contributions from each of the member companies come together to create the specifications.

Technical Workgroups

These subgroups are very active and each of the following is responsible for a distinct area:

- Architecture (70 members)
- SA Forum-OSDL (18 members)
- Hardware Platform (64 members)
- Application Services (51 members)
- Systems Management (111 members)
- Application Interface Specification (123 members)

Marketing Workgroup

It is the role of the Marketing Workgroup (MWG) to promote the adoption of SA Forum specifications. This is achieved through an active recruitment campaign and conventional PR along with outbound marketing activities. The MWG is also very much involved in establishing requirements and working with the technical subgroups to ensure that delivered specifications meet the needs of the market. The Marketing Workgroup currently has 62 members.

Compliance Workgroup

As with any standardization effort, ensuring adherence and compliance to the specifications is crucial to the goals of portability and compatibility. At this time, the SA Forum maintains a product registry where members can submit self-certified documentation related to the conformance of their specific offerings to the relevant specification(s).

The SA Forum is working on an independent compliance mechanism through a third party. This will allow any vendor to submit products for testing, and the results of the tests will be used to verify compliance to each applicable SA Forum specification. Full details of the compliance testing program will be announced later this year. The Compliance Workgroup currently has 24 members.

Collaboration

Participation and collaboration within any standards body represents similar challenges. Members of the various working groups

Embedded Ethernet

only \$98 qty 1

- 10Base-T Ethernet
- 186 Processor @ 40 MHz
- DOS w/ Flash File System
- Hardware Clock / Calendar
- 512K DRAM & 512K Flash
- Console / Debug Serial Port
- 16 Digital I/O lines
- Optional DiskOnChip
- 5V DC Power
- Compact 3.75" x 2.50"



- (2) Serial Ports
- (2) 16-bit Timers
- Watchdog Timer

Expand with the pico-I/O

- 32 Digital Inputs
- 20 Digital Outputs
- 11 Channels of 12 Bit A/D
- C/C++ & Quick Basic Drivers

Call **530-297-6073** Email sales@jkmicro.com
 On the web at www.jkmicro.com

JK microsystems

RSC #21 @ www.embedded-computing.com/rsc

are from different companies and often different countries. This makes the use of electronic and asynchronous communication essential.

E-mail, website document repositories, and message reflectors are the primary methods used by all the groups for ensuring everybody in the work group stays in lockstep. Most groups hold frequent (usually weekly) conference calls where topics and issues can be discussed live.

The SA Forum holds quarterly *face-2-face* meetings that the majority of workgroup members attend. Lasting two or three days, these meetings allow for concentrated and detailed sessions to be held with each workgroup.

They are usually very lively and productive meetings and set the tone for the next period of electronic activity. While such a modus operandi may sound difficult, it allows members to balance their day jobs with the needs of the SA Forum. Moreover, it ensures the goals and objectives are monitored and achieved on schedule.

Summary

The benefits of SA Forum membership for companies and individuals are numerous. Standardization brings technological and economy of scale benefits to the industry through the collaboration and interaction of industry experts in their respective fields. All members are able to realize the opportunity to help develop and shape the future of highly available systems solutions while networking with their peers.

The use of COTS system platforms in the communication infrastructure is inevitable. The development of applications that can

leverage this equipment, while maintaining the availability needs of carrier-grade systems, is a challenging task.

However, by creating service availability interface specifications, and deploying building blocks that conform to those specifications, the members of the SA Forum are creating a new technology ecosystem for the rapid development of COTS solutions that can meet that challenge.

Service Availability is a trademark of the Service Availability Forum in the United States and other countries. Other company product and service names may be the trademarks or service marks of others.

Jon Kenton is the Strategic Marketing Manager for Motorola Embedded Communications Computing. He has 24 years of experience working in the computing and communications industry. Jon has extensive business and marketing experience and his formative years were spent as a Design Engineer with degrees in Electronic Engineering, Business, and Marketing. Jon is an active member of the SA Forum Marketing Workgroup.

Service Availability Forum

5440 SW Westgate Dr., Suite 217 • Portland, OR 97221

Tel: 503-291-2576 • Fax: 503-297-1090

E-mail: admin@saforum.org

Website: www.saforum.org

ELMA SYSTEM INTEGRATION

The Final Piece of Your Embedded Packaging Solution

At last, a complete embedded packaging solution that's simple and reliable! You'll work with an experienced engineer who will see your project through design, prototype, production and integration. Utilize our testing and verification resources to make sure your application meets agency standards, and your specifications. With everything done in one place, you save time and money on logistics. All you have to do is sit back and watch all the pieces fall into place.

ELMA
Your Solution Partner
US Elma Electronic Inc.
Phone: 510.656.3400 - Email: sales@elma.com - Web: www.elma.com

Standard Enclosures

- CPD/2.5k, ATCA, VES
- 19"/6U, Custom
- 19" and 22" Rack mount
- 1U to 14U
- 2 to 21 slots
- IEEE 1384.1b/13
- STMP

NPI Solutions

- Design
- Prototype
- Testing
- Manufacturing
- Assembly
- Integration

Testing

- Shock and Vibration
- EMC
- NRE
- Thermal Analysis

Certification

- FCC Class A, B
- UL, CSA, CE
- NRE Level III

RSC #22 @ www.embedded-computing.com/rsc

Modular Platforms



OUT OF THE BOX
SOLUTION

> www.atcatogo.com

The challenges facing service providers today with the data, voice and media networks are solved with AdvancedTCA® Targa Platforms. Diversified Technology, Inc. (DTI) continues its tradition of high performance, multiprocessing solution designs for the communication market with open standard AdvancedTCA® technology. Modular computing delivers the application provider a shorter time-to-market while leveraging off-the-shelf hardware solutions for a base platform. Experience DTI's Targa Systems today to enhance your next generation product.



AdvancedTCA®

DTI's Targa Series

- 5 and 14 Slot Rackmount Systems
- Single and Dual Intel® Xeon™ Processor based CPU Node Blades
- Hub Switch Boards
- MontaVista® Linux Carrier Grade Edition
- Multiple SBE® Network Interface Cards



- Telecom centric design offering scalability and capacity
- Turnkey solution providing system management, multiple fabrics and pre-installed Carrier Grade Linux OS
- Two separate switch engines capable of Gigabit Ethernet wire-speed switching
- Solution options including High Availability and Clustering
- Accelerated development for solution with pre-integrated, modular design
- Provides high levels of service availability

Call **1.800.443.2667** or visit our website at www.atcatogo.com

Diversified Technology®
An Ergon Co.

All trademarks and logos are the property of their respective owners.



By Markus Levy



Performance testing for digital entertainment systems

Multimedia has become the electronic industry's buzzword of the 21st century. That is because various forms of digital entertainment and communication have infiltrated almost every aspect of our lives, and the associated applications have become the main driver of semiconductor sales. Multimedia products include PDAs, mobile phones, MP3 players, digital cameras, camcorders, DVD players/recorders, TV set-top boxes, secure routers, broadband modems, and in-car entertainment systems.

Designing the applications and devices that fit into these systems requires a careful study of the balance between performance, power, and price. To facilitate this analysis, EEMBC has released a new suite of benchmarks for evaluating the performance of embedded processors in multimedia tasks.

DENbench suite

EEMBC's digital entertainment benchmark suite, called DENbench, expands on the consortium's first-generation consumer benchmarks. Specifically, DENbench is comprised of several mini-suites including:

- audio decoding
- image processing
- video processing encode
- video processing decode

Other benchmarks in the suite focus on encryption and decryption algorithms commonly used in Digital Rights Management (DRM) and eCommerce applications.

Although DENbench retains the JPEG and color-space-conversion tests from the old consumer suite, it adds a test for RGB to HPG conversion (a Hewlett-Packard graphics format), and applies seven new datasets for each benchmark test in this mini-suite. In support of the more robust systems available today, the datasets

include larger and more complex images for the data compression, decompression, and colorspace conversions. The scores from this mini-suite of image processing benchmarks are combined to derive a figure of merit called the *ImageMark*.

EncodeMark and DecodeMark

From the video perspective, DENbench derives two other figures of merit: the *MPEG EncodeMark* and the *MPEG DecodeMark*. For the MPEG EncodeMark, a mini-suite implements MPEG-2 video encoding with integer math, plus an MPEG-4 video encoder. For the MPEG DecodeMark, a mini-suite performs MPEG-2 video decoding, MPEG-4 video decoding, and MPEG-2 Layer 3 (MP3) audio decoding. Each of these tests uses five datasets. The MPEG-2 encoding tests use algorithms adapted from the International Standards Organization (ISO), and include Huffman compression and modified inverse Discrete Cosine Transform (iDCT) routines.

CryptoMark

The EEMBC *CryptoMark* is an aggregation of four benchmark tests for common cryptographic standards and algorithms:

- Advanced Encryption Standard (AES)
- Data Encryption Standard (DES)

- Rivest-Shamir-Adleman (RSA) algorithm for public-key cryptography
- Huffman decoding for data decompression

Putting DENbench through the paces

When EEMBC officially announced its new Digital Entertainment benchmark suite, the consortium also published the first certified DENbench scores from AMD, Analog Devices, Freescale, and IBM Microelectronics. The first processors to undergo the challenges of the new benchmarks are listed in Table 1.

Processor	Clock Speed
Analog Devices ADSP-BF533	600 MHz
AMD Geode NX1500	1 GHz
Freescale MPC7447A	1.4 GHz
IBM 750GX	1 GHz

Table 1

These processors represent a wide range of performance, power, and price characteristics and therefore help to validate the effectiveness of DENbench. The scores for the processors are shown in Table 2. All scores are Out-of-the-Box and were certified on November 23, 2004. The processors are all production devices.

Processor and Clock Speed	Power Usage	Compiler	MPEG DecodeMark	MPEG EncodeMark	CryptoMark	ImageMark	MPEG2 Encode (Floating Point)	DENmark
Analog Devices ADSP-BF533 600 MHz	0.5 W	Green Hills MULTI 4.2	N/A	355.5	N/A	N/A	N/A	N/A
AMD Geode NX1500 1 GHz	6 W	GNU License GCC 3.3.3	785.1	587.4	509.3	918.9	30.2	131.7
Freescale MPC7447A 1.4 GHz	18.3 W	Green Hills MULTI 4.0.5	1506.3	1281.5	1263.3	1709.4	67.2	257.6
IBM 750GX 1 GHz	8.3 W	Green Hills MULTI 4.0	1054	967.9	903	1090.4	N/A	173.6

Table 2

Artesyn Technologies equals



**infinite
customer-centric
advancements in
telecom technology
and quality**



Innovation, Commitment, Integrity, and Economic Value... These are qualities you'll often find at leading companies in today's global economy. They're also qualities you'll find at Artesyn Technologies, a worldwide leader in providing continuous advancements in technology and quality for wireless, switching, signaling, optical networking, and other telecom infrastructure applications. At Artesyn, we are at the forefront of change in creating the boards and software that help make worldwide Teledatacom™ networks and real-time communication systems for Telecom OEMs possible. We continuously research, test, and develop new technologies to provide our customers with solutions that are cost-effective, that strengthen their competitive positions, and lower their total cost of ownership. Want to glimpse the future of Teledatacom™ from the vantage point of a leader? Visit our Website at www.artesyncp.com or call us at **1-800-356-9602**.

ARTESYN
TECHNOLOGIES
Artesyn Communication Products

8310 Excelsior Drive
Madison, WI 53717-1935 USA
Toll Free: 1-800-356-9602
Voice: 1-608-831-5500
FAX: 1-608-831-4249
Email: info@artesyncp.com

www.artesyncp.com

Benchmark scores

The scores for the AMD processor were derived by ECL, the EEMBC Certification Lab, to help test and calibrate the DENbench suite. To produce solid baseline code, ECL used a generic GNU compiler (GCC 3.3.3) and did not set the compiler's performance-optimization flags (-Ospeed and the microarchitecture-specific -cpu switch). Tested in this manner, the Geode NX1500 scores do not reflect the processor's true potential.

On the other hand, the other three processor scores were generated using the Green

Hills MULTI compiler. The Freescale and IBM processors are the most similar in this group, because they share the PowerPC architecture, but they do have substantially different microarchitectures and system implementations.

Out of the bunch, the chip with the highest overall *DENmark* score was the Freescale MPC7447A, which at 1.4 GHz also boasts the highest clock speed in this group. A comparison of these chips for performance per megahertz indicates that the PowerPC processors accomplished more work per clock cycle than the other

processors. But IBM's larger L2 cache (1 MB versus 512 KB) and its shorter pipeline give the 750GX an efficiency advantage over the MPC7447A on several of the benchmarks.

Power consumption

From a power consumption perspective, Blackfin takes the prize among these first processors benchmarked. Of course, that is only logical given the applications that this processor targets. Although its MPEG EncodeMark score was the lowest in the group, the Blackfin BF533 typically consumes only 0.5 W, significantly less than the 6 W for the Geode NX1500, 8.3 W for the 750GX, and 18.3 W for the MPC7447A. In a performance/Watt comparison, Blackfin is about seven times more efficient at MPEG encoding than the other processors.

DENmark, EncodeMark, DecodeMark, CryptoMark, and ImageMark are trademarks of the Embedded Microprocessor Benchmark Consortium in the United States and other countries. Other company product and service names may be the trademarks or service marks of others.

Markus Levy is founder and President of EEMBC. He is also Technical Editorial Director and Analyst at ConVergence Promotions. Mr. Levy received several patents while at Intel for flash memory architecture and for flash memory drives.

EEMBC – the Embedded Microprocessor Benchmark Consortium – was formed in 1997 to develop meaningful performance benchmarks for embedded system hardware and software. Contact the EEMBC directly for membership and certification information.

Gigabit Ethernet
10/100/1000-BaseT

Four ports
High availability

Three form factors
PCI/PCI-X, PMC, and AdvancedMC™

INTERPHASE
Designed To Perform. Designed To Last.

It's that simple.

Interphase.com (800) FASTNET

RSC #26 @ www.embedded-computing.com/rsc

Run better, faster and further with the right level of integration



Embedded Intel® Architecture provides you with design resources at multiple levels of integration: from Intel silicon and reference designs to validated board-level solutions from members of the Intel® Communications Alliance.

Run better. Intel building blocks help you choose the right balance of price and performance to meet customer demand now, with the headroom and scalability you need for next-generation solutions.

Faster. Choose the level of integration that matches your requirements: from meeting tight deadlines to trimming bill-of-materials costs and simplifying test and validation.

And further. Intel embedded lifecycle support and scalable embedded Intel Architecture platforms help you amortize development costs over the life of your product designs. The Intel embedded product roadmap is your direct route to the latest technologies.

Save time, money and engineering effort with embedded Intel Architecture. For more information visit <http://intel.com/info/eia>



intel.

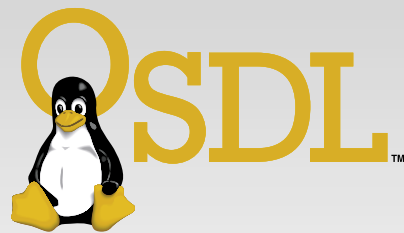

Carrier Grade Linux 3.0: Building out and looking forward

By Bill Weinberg

In February 2005, the Open Source Development Lab (OSDL) released the latest version of the Carrier Grade Linux (CGL) Requirements Definition – version 3.0. OSDL CGL builds on the strong adoption of the 1.1 and 2.0 releases, which now form the basis for half a dozen off-the-shelf Linux platform products and dozens of deployed systems from Telecommunication Equipment Manufacturers (TEMs) and Networking Equipment Providers (NEPs).

This article by Bill Weinberg of the OSDL provides insight into current Carrier Grade Linux adoption trends, and introduces readers to key innovations in Carrier Grade Linux 3.0. It also provides useful guidance to designers presently evaluating CGL implementations.

CGL 3.0 – the next generation

CGL requirements continue to evolve in response to needs expressed by TEMs, NEPs, and their customers at carriers and operator companies. The current 24 members of the CGL committee are listed in Table 1. The CGL committee has the following subcommittees and chairpersons:

- Marketing – Bob Monkman of MontaVista
- Technical – Terence Chen of Intel
- Steering Chair – Peter Badovinatz of IBM

Their input is amplified by the hundreds of customers represented by CGL supplier ecosystem members on the CGL technical and marketing working groups. In all, some two dozen CGL initiative members collect and integrate input from across the communications industry and around the world.

CGL adoption

The Carrier Grade Linux definitions act to drive the marketplace forward. Its leading-edge requirements respond to real-world needs, inspire original solutions by Open Source developers, and drive Linux-based

platform providers to deliver compliant shrink-wrap distribution products.

Today's CGL suppliers have made great strides in offering distributions and tool kits that are CGL 1.1 or 2.0 compliant, and adoption has grown as a result. Global TEMs, NEPs, and carriers deploying CGL are shown in the sidebar. Vendors have that have shipped or announced CGL compliant implementations are shown in Table 2.

Leading edge technologies and specifications need to pause every so often to take stock of adoption trends and

10art-ni	Comverse	IBM	Nokia	Sun Microsystems
Aduva	Ericsson	Intel	Novell	TimeSys
Alcatel	Fujitsu	LynuxWorks	NTT Corporation	TurboLinux
BakBone	Hitachi	MontaVista Software	NTT Data Intellilink	Wind River
Cisco	HP	NEC	Red Hat	

Table 1

Conectiva/Mandrake	Red Hat
Hewlett Packard	TimeSys
MontaVista	TurboLinux
Novell/SuSE	Wind River

Table 2

SIDEBAR

Global TEMs, NEPs, and Carriers Deploying Carrier Grade Linux

- Agilent UK
- Alcatel
- Cisco
- Datang
- Deutsch Telecom
- Ericsson
- Fujitsu
- Huawei
- Iskratel
- Lucent
- NEC
- NTT
- Nokia Networks
- Samsung
- Siemens

response to new initiatives. For that reason, Carrier Grade Linux 3.0 is best characterized as a *technology release* for evaluation by developers and Linux distributors. Solutions based on the CGL 3.0 requirements definition are expected to arrive in the marketplace in 2006.

CGL 3.0 innovations

Carrier Grade Linux offers additions and refinements to the existing CGL 2.0 requirements set, and expands the CGL definition to cover seven distinct areas:

- Availability – 5-nines (99.999 percent) availability is targeted with no downtime allotted for system maintenance and system expansion.
- Serviceability – Enables remote management and monitoring.
- Performance – Systems must meet service deadlines in real time, and support Symmetric Multiprocessing (SMP), multithreading, and large

memory systems. Systems must also provide efficient, low latency communications.

- Standards – Compliance with standards for interoperability such as the Linux Standard Base, SA Forum Application Interface Specification (AIS), and POSIX.
- Hardware – Support for standards-based COTS hardware components, with support for hot swap and high throughput interconnect.
- Clustering – Removal of single points of failure for both hardware and software.
- Security – Provides a framework for securing both management interfaces and content streams.

Clustering

Scrutiny of real-world requirements dictated by actual TEM and NEP usage reveals that no single clustering paradigm meets the needs of all carrier class applications. Rather than attempt to invent an omnibus cluster definition, CGL 3.0

PLATFORMS COMPONENTS SOFTWARE



ADVANCED MANAGED PLATFORMS

- ✓ Shelf management through all components
- ✓ World-class switching
- ✓ Advanced power and cooling
- ✓ High availability and compatibility
- ✓ Easier integration and faster time-to-market
- ✓ 20 years experience developing standards-based technology

**Platforms. Components.
Software. Support.**

**Many solutions.
One vendor.**



**PERFORMANCE
TECHNOLOGIES**

www.pt.com

(585) 256-0200

info@pt.com

RSC #29 @ www.embedded-computing.com/rsc

defines a set of components that comprise a CGL High Availability Cluster (HAC) as shown in Figure 1.

A CGL HAC represents a functional common denominator and is characterized as a set of at least two computing nodes that support migration by applications or workloads among those nodes. Externally established policy mechanisms determine:

- how nodes work together
- how nodes distribute loads
- which types of failover to support

The CGL HAC definition also accommodates the two divergent rationales for using clusters; to provide higher service availability (primary), or to scale compute or storage capacity (application determined).

Clustering for high availability

Broadly speaking, clustering is a key means

to achieve up-times of 5-nines or better. Availability is defined in terms of both Mean Time Between Failures (MTBF) and Mean Time To Repair (MTTR), and clustering can enhance both factors.

Any type of cluster increases MTBF by sharing the risk among multiple nodes and by eliminating single points of failure. A CGL HAC improves MTTR by supporting rapid repair and replacement methods like hot swap, and also by specifying that systems offer failover in sub-second time frames and boot/reboot in seconds.

The base configuration for a CGL HAC is a 1+1 hot standby cluster with one active node and one on standby. CGL HAC implementations can extend this basic definition to include additional active nodes (M) and/or stand-by nodes (N) as needed by an application or specified by policy.

Unlike enterprise clusters or those used in grid computing, most telecommunications applications are well served by loosely-coupled clusters without shared storage. This simpler scheme eliminates

the possibility of a failed shared component affecting the availability of the service or the system as follows:

- Eliminates single points of failure – Operators can replace or repair failing nodes without impacting service up-time.
- Supports in-place system and application upgrades – Allows maintenance of software and hardware without affecting availability of service.
- Isolates faults – Segregates failing nodes from the cluster and enables the continuation of service with the remaining healthy nodes.
- Scales Capacity – Offers increased capacity to meet varying loads or traffic.

SA Forum AIS compliance

CGL 3.0 clustering requirements build on industry-standard programming interfaces. These standard APIs include the Service Availability Forum (SA Forum) Application Interface Specification (AIS) for clustered applications. AIS is operating system independent and applies equally to proprietary and open source cluster paradigms.

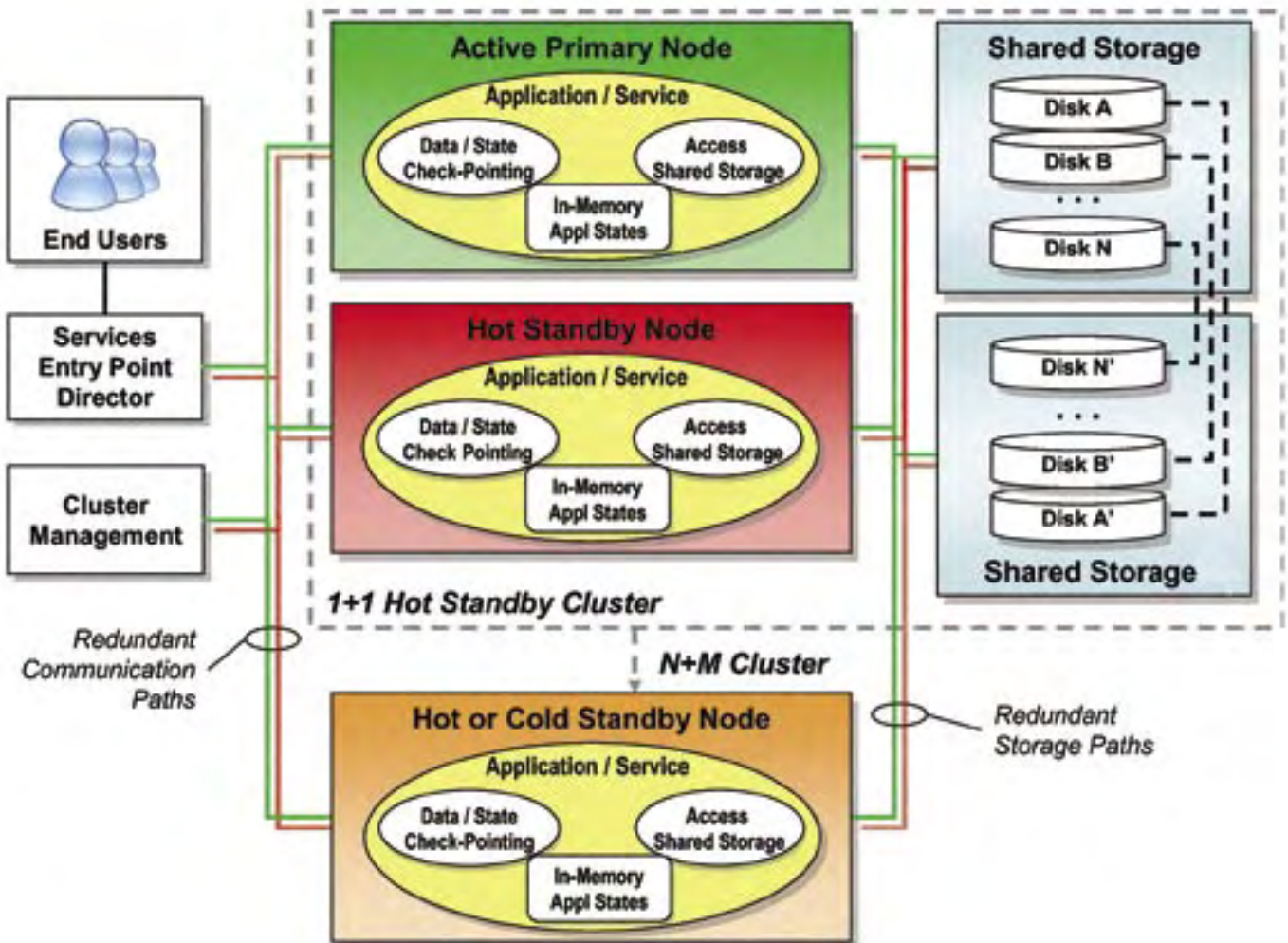

Figure 1

The SA Forum AIS specifies a family of APIs including Membership Service, Checkpoint Service, Event Service, Message Service, and Locking. AIS also specifies an Availability Management Framework (AMF) that provides resource management and the application failover policy for a cluster.

CGL 3.0 security requirements

Traditionally, telecommunication applications differed from general-purpose computing environments in several key aspects:

- telecom systems did not have many user accounts
- user accounts did not reflect individual users
- telecom systems were configured through custom user interfaces instead of logon shells

In today's IP-based world of convergent voice and data, a range of new security risks has emerged that directly impact systems built on Carrier Grade Linux:

- Use of general-purpose systems for IP-based computer telephony, PBX, voicemail, and VoIP applications
- Extensive use of in-band management interfaces
- Exposure of networks from unsecured or misconfigured IEEE 802.x wireless interfaces
- Spoofing of wireless client device IDs and BlueTooth exploits and viruses
- Cracking management systems from insecure Common Gateway Interface (CGI) interfaces

Management and control threats

According to TEMs and NEPs, the greatest threat to the communications environment comes from access to management and control interfaces by unauthorized parties. A common point of access comes from the self-provisioning of data or voice services by end users.

For example, many ISPs and VoIP service providers allow customers to create new mailboxes or route incoming calls from internal extensions to any e-mail address or telephone number in the world with just a few clicks on a web page. Facilities like these create a new set of risks:

- Unauthorized rerouting of e-mail and telephone calls by disgruntled associates or unscrupulous competitors
- Exploitation of vulnerabilities in software to jump from one security plane to another, opening new avenues for security exploits

CGL 3.0 security features

Mitigating these and other risks requires both carefully elaborated security policies and robust authentication schemes. Moreover, while many options exist for securing versions of enterprise Linux against intrusion and subversion, relatively little investment has been made to date with regard to dedicated Linux-based communications systems.

In recognition of the evolving nature of the field, the CGL working groups have elected to postpone publication of the security section of the 3.0 CGL definition until later in 2005. In the interim, member companies are solidifying their requirements for securing CGL platforms. The OSDL, for its part, has established a Security Special Interest Group (Security SIG) to generate one or more CGL security profiles and a unified architectural approach for security on communications servers.

"...the greatest threat to the communications environment comes from access to management and control interfaces by unauthorized parties."

CGL compliance and registration

Strictly speaking, CGL is not a standard, but is rather a family of specifications that include compliance to POSIX, LSB, SA Forum, and other pre-existing and evolving standards. As such, the OSDL does not establish a compliance or conformance discipline, complete with test suites and certification regimens. Moreover, many CGL Priority 1 and Priority 2 requirements can be satisfied through multiple Linux-based mechanisms (as with clustering or real-time responsiveness).

In this context, Linux providers with a communications-directed distribution or platform that wish to use the Carrier Grade Linux brand are required to register their platform's adherence to the particulars of the CGL Requirements Definition. Furthermore, they must publish a registration document that calls out their products' implementation of each requirement and provides proof of compliance or conformance to standards implicated in the CGL definition.

PLATFORMS COMPONENTS SOFTWARE



INTEGRATED COMPONENTS

- ✓ Fully managed platforms
- ✓ Ethernet switches, I/O communications and SBCs
- ✓ Media, voice and packet processing
- ✓ SS7/IP solutions
- ✓ CompactPCI®, 2.16, PCI, PMC
- ✓ Supporting software including NexusWare™ and WAN Protocol kits
- ✓ 20 years experience developing standards-based technology

**Platforms. Components.
Software. Support.**

**Many solutions.
One vendor.**



**PERFORMANCE
TECHNOLOGIES**

www.pt.com

(585) 256-0200

info@pt.com

RSC #31 @ www.embedded-computing.com/rsc

Embedded Computer Solutions For Harsh Environments -40°C to 85°C Operating Temperature

Five year product availability
guarantee

1.26GHz Pentium III System On Module

\$US 275.00/each

(OEM Qty. 900MHz CPU,
256K L2 cache)

- Choice of ultra low power Tualatin Pentium III / Celeron CPU from 500MHz to 1.26GHz with 256/512 KB L2 cache
- Up to 512MB SDRAM
- Intelligent thermal management with independent microcontroller
- Over 200,000 hours MTBF
- 5V @ 2.2A, 3.3V @ .7A with 900 MHz CPU and 256 MB memory



Front View

Back View

- PCI/LPC/SMB Bus
- CRT/LCD video
- Dual channel enhanced IDE
- 10/100Base-T
- AC'97 2.2 Audio
- 2 RS232 Ports
- 1 LPT Port
- 4 USB 1.1 Ports
- 8 GPIO Ports
- Keyboard and Mouse
- +3.3V

High Density Connector



Pentium III EBX SBC designed for Mobile and Outdoor Applications



- 500MHz to 1.26GHz Pentium III CPU
- Ultra low power
- Passive Heat Sink for CPU up to 900MHz
- 14W (using 900MHz CPU, 256K L2 cache)
- -40°C to +85°C operating temperature

- Soldered Onboard 256MB SDRAM (Optional 768MB with SODIMM)
- CompactFlash Disk (up to 6 Gbytes)
- LCD/CRT Video, 10/100Base-T Ethernet interface, AC'97 Audio, TV Out
- 6 serial ports, dual USB, 256 Bytes EEPROM, 64-bit unique electronic ID
- 128/512Kbytes battery backed SRAM with 10 years data retention
- Intelligent thermal management with independent microcontroller
- Less than 4 seconds boot up time
- 8" x 5.75" standard EBX form factor
- Supports DOS, Windows 98, NT, 2000, XP, CE, QNX, pSOS, Linux, VxWorks



Toronto MicroElectronics Inc.

5149 Bradco Boulevard, Mississauga, ON., Canada L4W 2A6
Tel: (905) 625 - 3203 ~ Fax: (905) 625 - 3717
sales@tme-inc.com ~ www.tme-inc.com

RSC #32 @ www.embedded-computing.com/rsc

CGL shopping guide

If you are embarking on a project to develop advanced voice and data products, Carrier Grade Linux platforms provide advantages in portability, reliability, performance, and development and deployment cost. However, not all Carrier Grade Linux implementations are created equal. Important CGL platform selection criteria are listed in Table 3.

Summary

Carrier Grade Linux adoption continues to expand, with equipment and services providers supporting renewed voice and data build-out with COTS hardware, and Linux and other open source software. TEMs, NEPs, carriers, and operators are building on Linux for its robustness, scalability, performance, and lower costs of acquisition and long-term ownership.

While legacy RTOS and other highly-purposed software continue to be needed for highly-specialized blades and real-time sensitive interfaces, the application domain of Carrier Grade Linux continues to expand.

The accompanying expansion of suppliers for Carrier Grade Linux solutions directly reflects the ubiquitous design-in that Free and Open Source Software (FOSS) and Linux enjoy in current and next-generation communications. Stay tuned for new Carrier Grade announcements from Linux platform providers and voice and data system suppliers throughout 2005 and 2006. **ECD**

Bill Weinberg brings more than 18 years embedded and open systems experience to his role as Open Source Architecture Specialist at the Open Source Development Labs. Bill can be contacted at bweinberg@osdl.org.



OSDL – home to Linus Torvalds, the creator of Linux – is dedicated to accelerating the growth and adoption of Linux in the enterprise. Contact the OSDL directly for membership and lab usage information.

Open Source Development Labs, Inc.

12725 SW Millikan Way • Suite 400
Beaverton, OR 97005

Tel: 503-626-2455 • Fax: 503-626-2436

Website: www.osdl.org

Selection Criteria	Selection Comments
Registration <ul style="list-style-type: none"> ✓ CGL registration 	Strictly speaking, vendors may not promote a Linux distribution or cross-development kit as Carrier Grade Linux unless they have shown that their product implements all Priority 1 Carrier Grade Linux requirements. For a listing of Registered CGL products and registration documentation, visit: www.osdl.org/lab_activities/carrier_grade_linux/registration.html
CGL Version <ul style="list-style-type: none"> ✓ CGL 2.0 or later 	With the release of the latest Carrier Grade Linux Definition, there are now three evolutionary versions of the CGL specification: 1.1, 2.0, and 3.0. A number of early adopters have been shipping 1.1 compliant platforms for over two years; six vendors have announced or shipped CGL 2.0 registered products; new CGL 3.0 product announcements are expected after the CGL 3.1 definition release later in 2005.
Linux Kernel Version <ul style="list-style-type: none"> ✓ 2.6 kernel 	CGL 1.1-based implementations were all based on versions of the 2.4 Linux kernel. At present, CGL 2.0 platforms present a mix of 2.4 and 2.6 kernel technology, with 2.4-based implementations back-porting large amounts of enabling code from a 2.6 context (such as NPTL). Moving forward, you should look for 2.6-based CGL products.
CPU Support <ul style="list-style-type: none"> ✓ Intel IA-32 or AMD x86 ✓ Embedded CPUs 	Enterprise-oriented CGL platform products and distributions by definition target COTS hardware based on Intel IA-32 and AMD x86 architectures. More deeply embedded CGL implementations can target PowerPC Single Board Computers (SBCs). Targeted blades are based on PowerQUICC, MIPS, and Intel XScale CPU families. Note that it is common for embedded architecture implementations to support fewer CGL definition features than COTS Intel IA-32 or AMD x86 implementations.
SBC Support <ul style="list-style-type: none"> ✓ AdvancedTCA ✓ CompactPCI ✓ PC/AT 	SBC manufacturers today leverage the PC/AT core architecture and high performance Intel IA-32 or AMD x86 CPUs for COTS compatibility and cost savings. CGL builds on this core and at a minimum will boot on almost any Intel IA-32 or AMD x86 SBC in any form factor. CGL providers differentiate their platform offerings with system-specific hardware support, especially for different SBC and blade types, management capabilities (like IPMI), hot-swap and hot-plug support, and CPU and board support for application-specific blades and line cards based on PowerPC, ARM, MIPS, and other architectures.
Development Hosts <ul style="list-style-type: none"> ✓ Self-hosted ✓ Cross development 	With COTS Intel IA-32 or AMD x86 targets, the Carrier Grade device prototype itself is frequently used for self-hosted development. For larger development teams, more complex Carrier Grade applications, and more deeply embedded target CPUs, CGL suppliers should offer cross development options hosted on standard Linux, Solaris, and even Windows workstations.
Integrated Development Tools <ul style="list-style-type: none"> ✓ Eclipse ✓ CVS ✓ ClearCase 	Data and telecommunication projects are among the most complex types of embedded designs, often involving millions of lines of code, and dozens or even hundreds of developers. In the past, your organization may have looked to COTS vendors only for platforms or single tools. With next-generation CGL-based systems, your team should seek suppliers that integrate standard tools into development environments that interoperate with global development frameworks, code management tools, and project management software.
CGL Platform Value-Add <ul style="list-style-type: none"> ✓ Productization ✓ Support & services ✓ CGL registration ✓ Domain-specific value 	As with any type of open source product, CGL vendor value-add can come from Productization (integration, test, QA), Support (technical support, bug fixes, updates) or Services (customization, training). With CGL, the first value-add is definition compliance and registration of a fully-integrated CGL platform. Additional value-add comes from application-domain specific features: CPU and form-factor support.
Validation of M/W and Applications <ul style="list-style-type: none"> ✓ LAMP ✓ HA middleware ✓ IPMI ✓ VoIP 	Enterprise Linux distribution suppliers, the Free Standards Group, and the OSDL are working to make interoperability of system software, middleware, and applications as transparent as possible for all versions of Linux. However, when choosing a CGL implementation for your next project, you should work closely with your integration team, your CGL Linux supplier, and key ISVs to validate that your actual application workload is tested and fully functional. Commercial CGL providers add significant value through the technical side of their partnering programs with ISV-ware validation and assurance. If your CGL project does not build on Intel IA-32 or AMD x86 hardware, the builds from source, integration, and test will likely fall to your own team or to a third-party services company.

Table 3

PLATFORMS COMPONENTS SOFTWARE



ENABLING SOFTWARE & MIDDLEWARE

- ✓ NexusWare™ Linux-based software
- ✓ UniPorte™ media & voice processing
- ✓ High availability software kits
- ✓ Radar receiver, HDLC, frame relay, TADIL-B, X.25
- ✓ SS7/IP interworking
- ✓ T1/E1/J1 & serial drivers
- ✓ 20 years experience developing standards-based technology

Platforms. Components. Software. Support.

Many solutions. One vendor.



PERFORMANCE TECHNOLOGIES

www.pt.com

(585) 256-0200

info@pt.com

RSC #33 @ www.embedded-computing.com/rsc

Speed and endurance take many forms...



You decide...Linux ready on every board

WAN



LAN

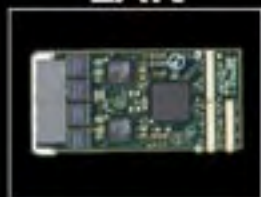

Storage



Carriers



Custom



SBE[®]

Linux On Demand

flexibility on demand | 925-355-2000 | info@sbel.com | www.sbel.com

RSC #34 @ www.embedded-computing.com/rsc

Industrial-strength security for ZigBee: The case for public-key cryptography

By Mitch Blaser

While the popular image of wireless networking usually features cell phones, PDAs, and laptop computers, there are all manner of other devices for which wireless networking presents great advantages. These devices are programmed to perform specific tasks or provide specific information accurately and reliably.

They range from managing automated lighting and heating systems in large buildings, to controlling and monitoring business-critical manufacturing processes. These industrial and commercial environments have demanding requirements in terms of network architecture, power consumption, operating cost, and perhaps most importantly, security. In this article, Mitch makes the case for public-key cryptography for ZigBee wireless networks.

Industrial and consumer security

Work performed by the ZigBee Alliance and the complementary work of the IEEE 802.15.4 standards group, promises to meet security requirements for industrial environments. Designed specifically for low-bandwidth, high-reliability applications – and with security as one of its core elements – ZigBee promises to deliver the benefits of wireless networking for industrial settings.

It also has wide applicability in consumer electronics, home and building automation, industrial controls, PC peripherals, medical sensor applications, toys and games.

Node determination

These networks may have a few, hundreds, or even thousands of nodes. As the networks grow, security and management will present a crucial requirement: to identify which node is responsible for what activity.

For instance, when a switch has the job of turning a machine off in case of emergency, it is critical that the command, issued over the network, is received by the correct device and then followed. Alternatively, when a device such as a temperature gauge or a light sensor fails or sends incorrect data, operators will want to know what happened and how to fix it. To do this, operators will need to know quickly and without doubt, which device is causing the problem, and how to prevent it from happening again.

System downtime

For these emerging wireless networks, any system downtime, whether from network failure, an unresponsive wireless device, or an active network attack is a failure to secure the network. In large-scale networks and critical applications built with ZigBee technology, it is essential to implement public-key cryptography that can be used to uniquely identify a node on a network, and then be able to securely send or retrieve data from that node.

With public-key cryptography, one key that only the device knows binds the device to its identity on the network; and a second key, mathematically related to first, is used by the network to verify that identity. This enables device identification to be performed rapidly, surely, and in a cryptographically strong manner.

ZigBee networks can use public-key methods to exchange keys and uniquely identify nodes. This identity can be used to manage the network device life-cycle and decrease management costs, while improving the security of the network and giving the network owner better control over the devices.

Why wireless?

As companies seek ways to reduce operational and support costs and capital investments in today's competitive global markets, production equipment must deliver reliability, availability, and maintainability. To do this, industry must improve production performance and safety while minimizing costs and extending the operational life of equipment.

Networked wireless sensors and manufacturing devices can enable real-time data sharing throughout a facility while adjusting to changing conditions to limit major failures. A 1997 study by a Presidential advisory board in the US indicated that wireless sensors could improve efficiency by 10 percent and reduce pollution emissions by over 25 percent.

In fact, the physical characteristics of some industrial environments make wireless the only viable networking option. In such cases, the notion of rolling out and maintaining a hardwire network is not only impractical but also prohibitively expensive. For example, some environments consist of an enormous number of devices or sometimes devices are not always easily accessible. Some applications are emerging because of this wireless connectivity; for example, vibration sensors on packing crates to limit breakage – an idea that would have been impossible using a wired sensor.

Ad hoc networks

ZigBee networks are built to operate in an ad hoc manner; that is, the nodes themselves establish communication paths, by communicating with nodes that are nearby. Routed networks like the Internet support multiple communications paths and reconfigure to let the network degrade gracefully if a node fails or an attack is executed on the network. This provides impressive robustness and stability. Ad

Your Leading Source For Ruggedized PC Solutions
With Unparalleled Longevity and Flexibility

RISC Embedded Solutions
System On Module
Biscuit SBCs
Slot CPU Cards
PC/104 Modules
POS Control Boards
Panel PCs
Embedded Operating Systems

We build to empower your innovations

With Advantech's innovative infrastructures and global service centers, we demonstrate our capacity to provide a full spectrum of highly-integrated hardware and software solutions on both x86 and RISC architecture.

Advantech's 30-Day DTOS™ (Design To Order Service) will provide you the shortest development time to bring your custom solutions guaranteed time-to-market, time-to-volume and cost-effective customized solutions.

Your ePlatform Partner
ADVANTECH
Embedded Computing

Toll Free: 1-800-866-6008 • Ph: 949-789-7178 • Fax: 949-789-7179
ECGInfo@advantech.com • www.advantech.com/epc
RSC #36 @ www.embedded-computing.com/rsc

hoc networks take this feature a step further, with each node able to provide routing rather than using central routers as the Internet.

Unlike other wireless networks, where multiple devices tend to connect independently to a single hub, without contact with other nearby nodes, ZigBee nodes can be interconnected to build a mesh architecture in which all nodes in close proximity can communicate. Popular wireless standards such as 802.11 and Bluetooth have less flexible topologies, making them less than ideal for industrial applications. Both are designed for hub-and-spoke environments, and are consequently unable to effectively support flexible configuration and mesh connectivity. An ad hoc network is shown in Figure 1.

Many of the conditions that make it difficult to hardwire a network in this type of scenario also make it difficult to provide devices with a hardwired power supply – which is precisely what an 802.11 network would require. Bluetooth permits battery

operation, but only for short periods of time. By its very nature, ZigBee overcomes these obstacles: devices are built to deliver years of operation from a single battery.

ZigBee power savings

ZigBee differs from other wireless networking protocols because it spreads an encoded signal across a broad spectrum. ZigBee uses Ultra-Wideband (UWB), a wireless transmission method that needs no carrier and means that data is encoded as a pulse train of low power Radio Frequency (RF) energy over many frequencies. This pulsing is much more efficient because it demands considerably less power than broadcasting a single, conspicuous power spike like 802.11 and Bluetooth.

ZigBee conserves further energy by powering down network elements when they are inactive. This significantly extends battery life, allowing devices to operate without the need of a hardwired power supply. As shown in Table 1, the advantages of ZigBee are clear for low-speed networks.

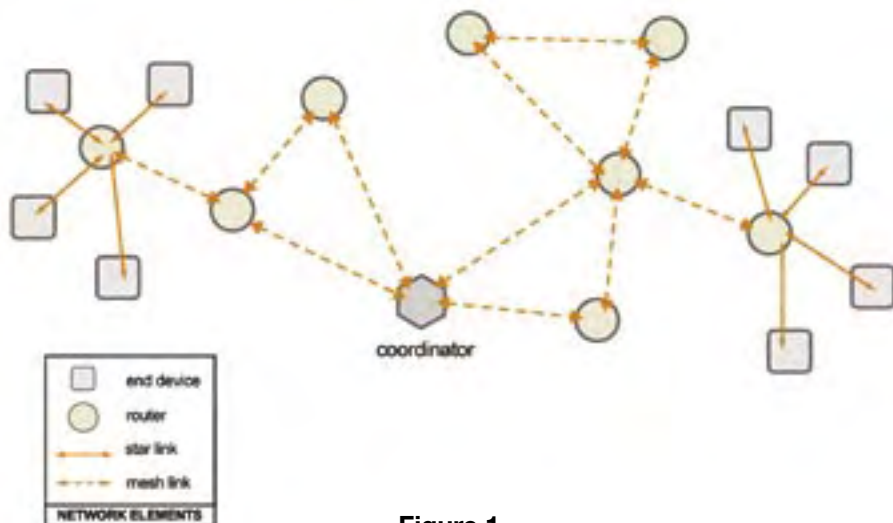

Figure 1

	ZigBee	Bluetooth
APPLICATION	Control & Monitoring	Cable Replacement
PROTOCOL STACK	32 Kb	250 Kb+
BATTERY LIFE	100-1000+ days	1-7 days
DEVICES/NETWORK	65,536	8
LINK RATE	20-250 Kbps	1 Mbps
RANGE	~ 30 meters	~ 10 meters
CHARACTERISTICS	• small packets/large network • static	• large packets/small network

Table 1

SMT287 PC 104 Disk Storage Solution



This is an example unit made up of SMT130 carrier and SMT387 module with 'C6415 DSP; Virtex II VP20; SATA Link; and Rocket Serial Link (RSL). In this solution the DSP can directly write to or read from Serial ATA hard disk supporting FAT32 filing system.

SMT290-VP7-5 PC 104 two channel ADC

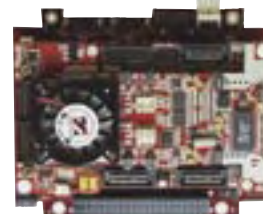

An ADC Module with 2-Channels of each sampling at 210MSPS @ 12bits. This is the first DAQ module to use a Virtex-II Pro FPGA and a unique 'Double-Decker' inter-connections concept that separate the Digital control functions from the noise-sensitive DAQ semiconductors.

SMT291 PC 104 two channel ADC

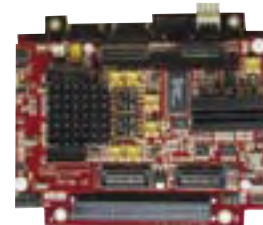

Built on the SMT391 module this combination provides a two channel ADC sampling at 1GHz per channel with 8bits resolution.

RSC #37 @ www.embedded-computing.com/rsc

SUNDANCE DIGITAL SIGNAL PROCESSING INC.
Tel: +1 775 827 3103 USA

SUNDANCE MULTIPROCESSOR TECH. LTD.
Tel: +44 01494 793167 UK

SUNDANCE ITALIA S.R.L.
Tel: +39 0185 385193 ITALY

sales@sundance.com www.sundance.com

A TRULY SCALABLE SOLUTION

Other ZigBee benefits

As mentioned previously, ZigBee is designed to support low-bandwidth data exchanges – which describe most industrial control and monitoring applications. The design enables fast, flexible, and inexpensive implementation. At the same time, these applications are mission-critical; consequently, expectations of reliability are exceptionally high. ZigBee provides that reliability and these other benefits:

- Cost savings – Installation without physical wiring will avoid the \$50 to \$100 cost per foot of wire (includes labor costs). In addition, robust, self-configuring mesh networks will save on maintenance costs.



Vigra®. The Clear Choice for Video, Imaging & Graphics.

Our Vigra products combined with our engineering and integration services are available today to get the job done. Your choice is clear. Visit us at www.titan.com or call us at 858.527.6100.

- Customizable, Flexible Platform
- FPGA-based
- Ruggedized Boards Available
- VxWorks® Solaris® Windows®
- Digital Video and Analog Video
- Compression/Decompression
- High Resolution, Low Bandwidth Video
- Real-time Image Processing
- PMC and PCI
- Audio
- Ethernet
- Graphics
- Dual Display
- On-Board Processing



Titan Corporation • Advanced Product & Design Division
titanapo@titan.com • 858.527.6100 • www.titan.com keyword: Vigra

RSC #38 @ www.embedded-computing.com/rsc

- Rapid commissioning – Installation and provisioning of devices can occur rapidly and without significant costs or physical construction.
- Flexibility – Placement of sensors in optimal locations allows a network to be adaptable and reconfigurable. In addition, placing sensors on all parts of an operation will allow applications never before considered for manufacturing, warehouses, and operational facilities.
- Reliability – Monitoring a large number of inexpensive sensors will offer improved control information, and capabilities to prevent failure and avoid system downtime.

In part due to these inherent benefits, a ZigBee network could be vulnerable to downtime or an attack if not properly secured. Security techniques built into the ZigBee design can ensure that a network is working properly, that only authorized devices are contributing data to an operation and that control information is sent to and from the correct devices.

Security features

ZigBee was created with security as a primary objective, using three main security-design principles.

- Every layer originating a frame is responsible for securing it. This simplifies the overall security solution, because multiple layers are not responsible for securing the same frame.
- Only one key is exchanged between a source and destination device, irrespective of the layer in which the message originates.
- An end-to-end security model is applied throughout; messages are routed independent of trust considerations because only the source and destination devices in any given exchange have access to the shared key. Data can therefore proceed across multiple hops without having to be decrypted and re-encrypted at each hop.

Advanced Encryption Standard

ZigBee uses the Advanced Encryption Standard (AES) for symmetric encryption because not only is it stronger than other options, it is faster and can be inexpensively implemented in hardware. The AES hardware implementation is much faster than a software implementation. In a short period of time, the cost of designing it into the hardware can be recouped as AES is small enough to fit into small sections of unused space within a device. Additionally, AES

is specified as a standard for US government use by the National Institute for Standards and Technology (NIST) under the Federal Information Processing Standard (FIPS) 197.

By definition, a symmetric algorithm means communicating parties use the same key to encrypt and decrypt the messages; but the two communicating parties must find a way to agree on a symmetric key. Therefore, although AES is the symmetric algorithm of choice for ZigBee, it is only part of the security equation.

Elliptic Curve Cryptography

Currently, ZigBee uses Symmetric-Key Key Exchange (SKKE), based on AES, to establish keys between communicating nodes. However, the best approach is to dynamically establish keys between communicating nodes as necessary, through the use of using public-key algorithms based on Elliptic Curve Cryptography (ECC). This offers distinct advantages for key exchange including scalability and non-repudiation.

ECC is ideal for ZigBee because it offers the most security per bit of any public key scheme. Traditional public-key systems, such as RSA, DSA, and Diffie-Hellman (DH) have been widely used for over 20 years. While they have served us well, they are too big and slow to include in constrained environments without severely impacting design choices and profit margins. ECC corrects this problem. Based on the elliptic curve discrete logarithm problem, these public-key algorithms have the benefit of faster computations and smaller key sizes for comparable security.

Key establishment

An elliptic curve version of the Menezes-Qu-Vanstone (MQV) scheme is proposed

“...a symmetric algorithm means communicating parties use the same key to encrypt and decrypt the messages; but the two communicating parties must find a way to agree on a symmetric key.”

as the key establishment mechanism for ZigBee. MQV is an efficient public-key agreement scheme that offers key authentication and key establishment in one calculation. NIST currently has a draft Special Publication, referred to as SP 800-56, which specifies an Elliptic Curve version of MQV (ECMQV) as the key agreement mechanism for US Government use (Figure 2).

The well-known Diffie-Hellman was not used because it requires two sets of calculations and exchanges, one for key agreement and one for authentication, to set up a secure channel. Like AES, ECMQV is fast, strong, and can be inexpensively implemented in hardware. In addition, by using elliptic curve methods, key sizes will be kept small even as security needs increase.

ZigBee also includes numerous key transport services that contribute to the reliability of the overall system. Key re-establishment and refresh capabilities

MQV Key Agreement

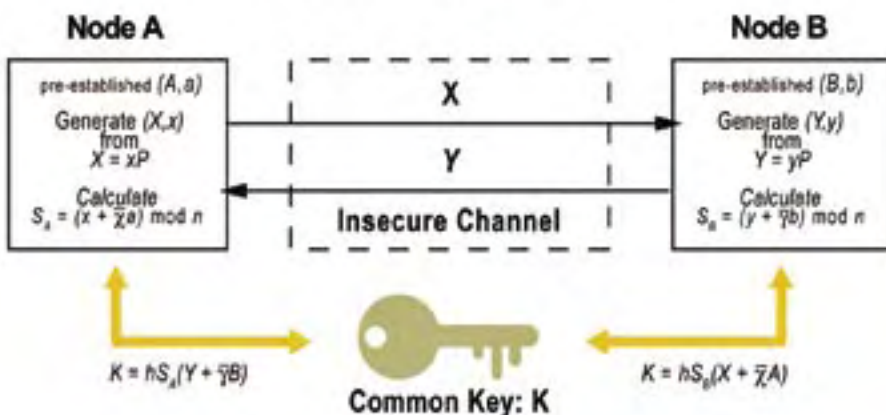

Figure 2

SMT118 Stand Alone Module Carrier



Responding to increasing demand for portable and embedded DSP solutions brought about SMT118, a truly 12V-Input stand-alone carrier. The SMT118 has been developed to carry 3 Modules and attention to power-management enables it to be powered by a small battery source! The SMT118-LT is lower cost version with less I/O pins.

SMT148 4 sites stand alone module carrier



The SMT148 carrier has 8 on-board channels of 400KHz analog inputs and outputs, three UART connections (one RS485 and two RS232), 56 pairs of LVDS connections, JTAG Debugging, an RSL, an SHB, two USB's and two FireWire (1394b) ports. There are 32 LEDs connected to the VirtexII Pro to enable a display.

SMT180 8 sites stand alone module carrier

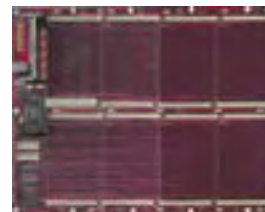

The SMT180 is an extension of the path created by SMT118. The SMT180 has taken the step of Stand-alone operation to another level as two SMT180s can be cascaded and provide a platform for no less than 16 Modules. If each module were an SMT374 it would offer in excess of 40GFlops of DSP Processing that can be integrated into a 0.5 cubic meter box and run from a car battery and still keep cool.

SUNDANCE DIGITAL SIGNAL PROCESSING INC.

Tel: +1 775 827 3103 USA

SUNDANCE MULTIPROCESSOR TECH. LTD.

Tel: +44 01494 793167 UK

SUNDANCE ITALIA S.R.L.

Tel: +39 0185 385193 ITALY

sales@sundance.com www.sundance.com

RSC #39 @ www.embedded-computing.com/rsc

A TRULY SCALABLE SOLUTION

Embedded Computer Solutions For Harsh Environments -40°C to 85°C Operating Temperature

Five Year Product Availability
Guarantee

EMBEDDED COMPUTER

Fanless Dust Tight High Performance Embedded Computer for Outdoor, POS, In-Vehicle, Marine or Applications.

- Pentium M / Pentium 4 / Celeron CPU from 1.3GHz to 2.1GHz
- Over 200,000 hours MTBF



DIGITAL VIDEO RECORDER

In-Vehicle Fanless Rugged Digital Video Recorder

- Up to 8 Video and Audio Channels @ 704x480 resolution (D1), 30fps per channel
- Operated from 7V ~ 28V DC-IN
- +12V DC Out for cameras
- Anti-vibration and anti-shock mounting kit

POINT OF SALE SBC

Ultra low power Embedded Computer designed for POS terminals

- Fanless operation from 200MHz to 900MHz Intel Tualatin CPU, on-board memory, LAN, CRT/LCD, Touch Screen, AUDIO, 6 Serial, 2 USB ports
- Over 250,000 hours MTBF



SYSTEM ON MODULE (SOM)

Design your own or have TME design a custom I/O board to be used with TME's SOM

- From 800MHz to 3.4GHz CPU
- Small form factor 5.5" X 4"
- Up to 1.5 GBytes soldered on-board DDR memory
- ISA, PCI, PCI-Express expansion

EBX FORM FACTOR SBC

Pentium III 1.2GHz EBX SBC designed for **Mobile** and **Outdoor Applications**.

- Ultra low power, Passive Heat Sink for CPU up to 900 MHz, soldered on-board 256MB SDRAM
- CRT/LCD, Audio, LAN, 6 serial, 4 USB 1.1, Intelligent thermal management, PC104+ expansion



PC/104-PLUS SBC

High Performance PC/104-Plus Embedded Computer (1.2GHz Pentium III)

- **Fanless** up to 900MHz
- CRT/LCD, LAN, PCI on PC104+, ISA on PC104 connectors, 2 serial ports, dual USB, 256 Bytes EEPROM, 64-bit unique electronic ID

public-key
cryptography

are all built in, enabling ZigBee to offer flexible and robust security policy management capability. By verifying endpoints through its public-key exchange mechanism, ZigBee can provide strong authentication mechanisms, building on a secure foundation.

Building for strength

In addition to using proven, efficient algorithms such as AES and ECC, there are a number of elements that can make the low-power wireless networks robust and secure:

- Key management – Distribution of keys is one of the functions that maintains the integrity of the network. You need to ensure that the key exchange protocols used do not compromise the system by using weak keys or impact the performance of the device.
- Reliability – Improved system up time can result if protocols are engineered to be sure that the wireless network is always networking; this could include a heartbeat function and management polling.
- Configuration management – Fast enrollment of devices, two-way identity exchange, and rapid decisions as to trust relationships will be critical in making devices work together.
- Policy management – Segmentation of the network and determination of what objects can provide what functions are important in a wireless world.
- System integrity – Security protocols can ensure that the network and the sensors themselves are working properly.

ZigBee applied

To appreciate the advantages of ZigBee as a wireless standard – and its security capabilities in particular – it is helpful to consider a real-world example: a manufacturing operation with assembly, packaging, and shipping functions. Each has its own control and monitoring requirements, and each depends on the others for the operation as a whole to achieve optimum output (Figure 3).

Data communications in such an environment take advantage of ZigBee's ad hoc capability. As sensors on machinery and packages move past control nodes on manufacturing equipment, the network reconfigures as the topology changes. ZigBee allows for efficient point-to-point communications. As parts of the



Toronto MicroElectronics Inc.
5149 Brasco Boulevard, Mississauga, ON., Canada L4W 2A6
Tel: (905) 625 - 3203 ~ Fax: (905) 625 - 3717
sales@tme-inc.com ~ www.tme-inc.com

RSC #40 @ www.embedded-computing.com/rsc

WY13

"In addition to using proven, efficient algorithms such as AES and ECC, there are a number of elements that can make the low-power wireless networks robust and secure..."

manufacturing and shipping operations move or act in relation to each other and share data, the identity of each node must be clearly identified, and the authenticity of communications – the knowledge that a particular communication is from a particular node – must be certain.

The ZigBee solution

Versatile and reliable, ZigBee presents a simple, low-cost solution for wireless networking in industrial monitoring and control environments. In addition, it is relevant outside of the exclusively industrial arena as well, with applications in consumer electronics, computing, and personal health care.

Network implementations often struggle to reach an acceptable compromise among considerations of performance, security, and cost. ZigBee delivers all three, making it the standard for many kinds of applications.

In ad hoc networks, where nodes may be mobile or transient, the identity of a node is essential to its participation in a network. Public key-based identities deliver stronger security within the constraints of process and control networks – meeting the real-world demands of applications from smart badges and building-systems automation to industrial and medical devices.

ZigBee is an excellent standard for industrial and commercial wireless networking environments. Moreover, public key security based on ECC reinforces ZigBee's strengths, making possible truly robust wireless networks. **ECD**

Mitch Blaser specializes in the application of cryptographic protocols and elliptic-curve cryptography to real-world problems at

Certicom Corporation.

Prior to Certicom,

Mitch held market

development and

product management

positions with Alcatel,

Newbridge Networks,

and TimeStep special-

izing in network

security and cryptographic applications.

Mitch holds a MSc in Telecommunications

from Southern Methodist University in

Dallas.



For more information, contact Mitch at:

Certicom Corporation

5520 Explorer Drive

Mississauga, ON L4W 5L1

Tel: 905-507-4220

Fax: 905-507-4230

E-mail: mblaser@certicom.com

Website: www.certicom.com

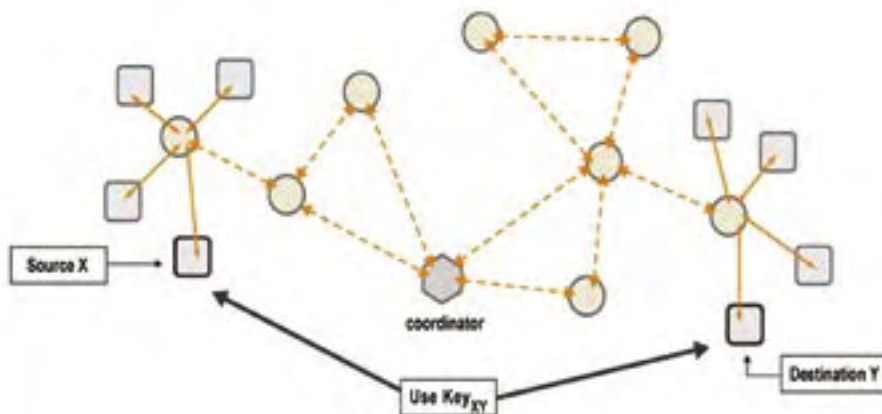

Figure 3

SMT6050

Simulink® - Toolbox for DSP
code generation and co-design



SMT6050 generates optimized C code from Simulink model and creates Target DSP code without needing to learn details of underlying hardware. SMT6050 adds functionality to MATLAB for interacting with running application on the DSP. While parts of application run on the host PC, the DSP can have access to the Matlab's powerful GUI.

Diamond RTOS

with true support for Multi-DSP



Diamond provides the best tools for fast development of multi-processor DSP projects on systems using one or many C6000s. Compilation, linking and debugging are done using Texas Instruments' Code Composer Studio, to which Diamond adds a comprehensive framework for multi-processor software development.

GDD600 & GDD8000



GDD600 Floating Point computation on Fixed Point TMS320C6000. A set of over 100 functions and macros for DSP operations like FFT, Fast Hartley Transform, FIR/IIR filters, vector, complex number arithmetic, and data conditioning (spectral windows). These are performed on the IEEE-754 Floating Point format. A set of data conversions functions is available to convert FP data to/from integer and Q15 fixed-point formats. Unlike other libraries in the market all GDD libraries are fully interruptible and re-entrant. With a single instance of any function linked in, all application threads can make a call to it simultaneously.

GDD8000 Hand coded EISPACK library for solving eigenvalue/eigenvector problems on TMS320C6000. The library is a set of about 100 functions and macros that find a solution to a linear algebraic eigensystems with various matrices, real or complex, general, band, symmetric or Hermitian. All or selected eigenvalues and eigenvectors can be computed. Several types of matrix decompositions like SVD or QR are performed by the library functions.

SUNDANCE DIGITAL SIGNAL PROCESSING INC.

Tel: +1 775 827 3103 USA

SUNDANCE MULTIPROCESSOR TECH. LTD.

Tel: +44 01494 793167 UK

SUNDANCE ITALIA S.R.L.

Tel: +39 0185 385193 ITALY

sales@sundance.com www.sundance.com

RSC #41 @ www.embedded-computing.com/rsc

FLEXIBLE AND POWERFUL SOFTWARE

JACYL TECHNOLOGY



Advancing Today's Technology Into Tomorrow



We specialize in completely
reconfigurable and reprogrammable
Digital FPGA and Analog FPAA
PC/104 Boards.

We're Your Project's Solution.

www.jacyltechnology.com

Implementing distributed automotive

telematics more efficiently

By Eugene Buechele

Traditionally, most embedded systems have been expected to operate autonomously. However, embedded systems are now expected to form an integral part of a much larger and more complex distributed system. Embedded systems are no longer just control units, they are becoming the delivery vehicles for new, network-based services that can be used by vendors to drive long-term revenue streams.

One example is the growing use of telematics in automobiles, where traditional development techniques cannot keep pace with the market demand for innovation. Automotive companies are demanding much faster turnaround for telematics, which have grown in complexity four-fold over just a couple of years, especially compared to the control systems that drive the rest of the car.

This demands an approach to development that is both faster and more flexible, while maintaining the same level of reliability expected by automotive manufacturers. A data-centric approach to the development of complex systems such as telematics offers a way of streamlining the process and of improving the system's flexibility.

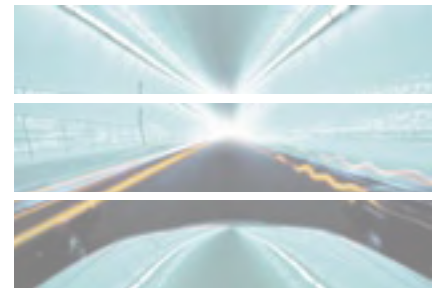

Telematic systems

Until now, most telematics system components have operated in isolation. For example, the navigation subsystem that makes use of Global Positioning System (GPS) information operates independently of a cellular-phone system used by the driver to make and receive calls. However, that same channel can be used to provide regular updates to the positioning subsystem.

Other subsystems are continually being added to meet the demand for new driver information services. For example, a voice recognition component can recognize key words in normal speech and offer both word recognition and syntax information to provide control of other components. In addition, a Value-Added Services Directory (VASD) component can store frequently dialed telephone numbers, businesses, landmarks, and addresses. Combining a wide variety of telematics systems into a



single system allows extensive data sharing (Figure 1).

Already in production today, advanced telematics systems are now employing digital broadcast systems. For example, XM radio and 3G wireless transfer digital information to each vehicle and provide a delivery channel for up-to-date value-added information to specific vehicles based on vehicle type, location, account status, and identity.

Seamless integration example

One key requirement in the development of advanced systems is the ability to tie the independent systems together in a manner that appears seamless to the user. Take the situation where the driver asks the system to “find an Italian restaurant with parking near the Grand Central train station.” The result would be a set of choices, and once the driver makes a selection, the navigation system can provide driving directions to the chosen restaurant.

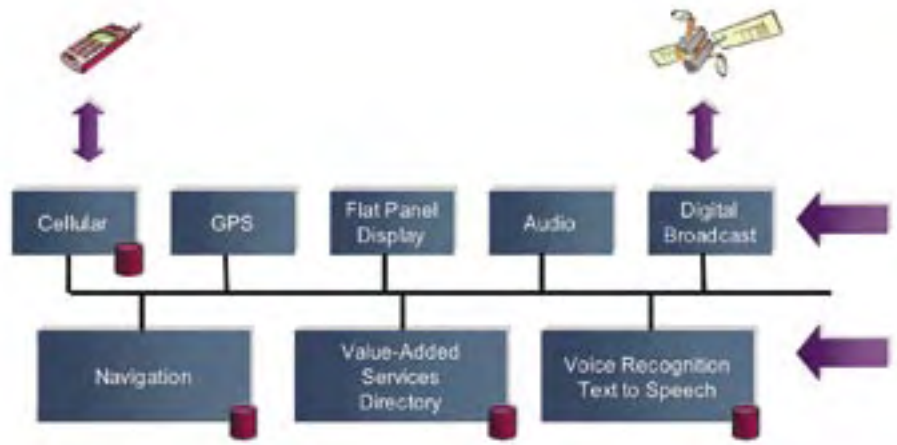

Figure 1

This apparently simple driver request would involve cooperation between a number of subsystems:

- the voice recognition component must recognize the individual words in the phrase
- isolate their meaning
- transform them into keywords
- retain their context
- pass the information to the VASD component

The VASD component would then:

- search the directory based on keywords and their context
- make requests to the navigation component to identify target restaurants
- determine the current location from the GPS component
- look up the most efficient route to the targeted location



Super Cool. Super Compact.
Superior PXH Cooling without Compromise.

Tailored PXH Thermal Solutions from Radian Heatsinks:

- Low-profile, high efficiency, removable BGA heatsinks for Intel® PXH Chipset applications
- Standard and custom PXH cooling solutions available for CompactPCI, ATCA, PC/104, PCI/104, EBX and other form factors
- EZ Snap™ Clip ensures easy installation, with no special board modifications needed
- Complimentary CFD Analysis, Design Assistance and Simulation Services provided
- Integrated Rapid Prototyping Capabilities
- Short-Run and Volume Production Solutions

for additional information, contact:
Radian Heatsinks
 a div. of Intecast Co., Inc.
 tel: 800.689.2802
 fax: 408.988.0583
 radiansales@radianheatsinks.com
 www.radianheatsinks.com



RSC #44 @ www.embedded-computing.com/rsc

To accomplish this synergy, an embedded data management engine needs to provide a number of services to the application to ease development and improve performance on low-cost hardware (Figure 2).

Voice recognition

The role of the voice recognition component is to transform (or *parse*) the spoken words into a set of keywords that are tagged to denote the type of each word. The context of the spoken phrase is preserved after the transformation by the ordering and structure of the keywords.

For example, "find an Italian restaurant near the Grand Central train station with parking" could be transformed into a set of ordered strings:

"Location <name> <address> <type> <attribute1> <attribute2>"

However, the example phrase must be transformed into more than one set of strings, as it calls for the location of:

- a candidate restaurant
- a restaurant near the Grand Central train station
- parking lot near the restaurant

Our example phrase would therefore parse into the following three data requests:

Location "name=?" "address=?" "type=restaurant" "attribute=Italian"

Location "name=Grand Central" "address=*" "type=train station" "attribute=*"

Location "name=?" "address=*" "type=parking" "attribute=*"

The goal of the VASD is to take the keyword structures from the voice recognition component as input, then return one or more location descriptors. These descriptors of locations can include name, address, telephone numbers, latitude and longitude, as well as a variety of audio or graphical elements for display (such as a company logo).

The VASD subsystem then must pass information based on these lookups to a text-to-speech component in the voice-processing subsystem. This information will include a set

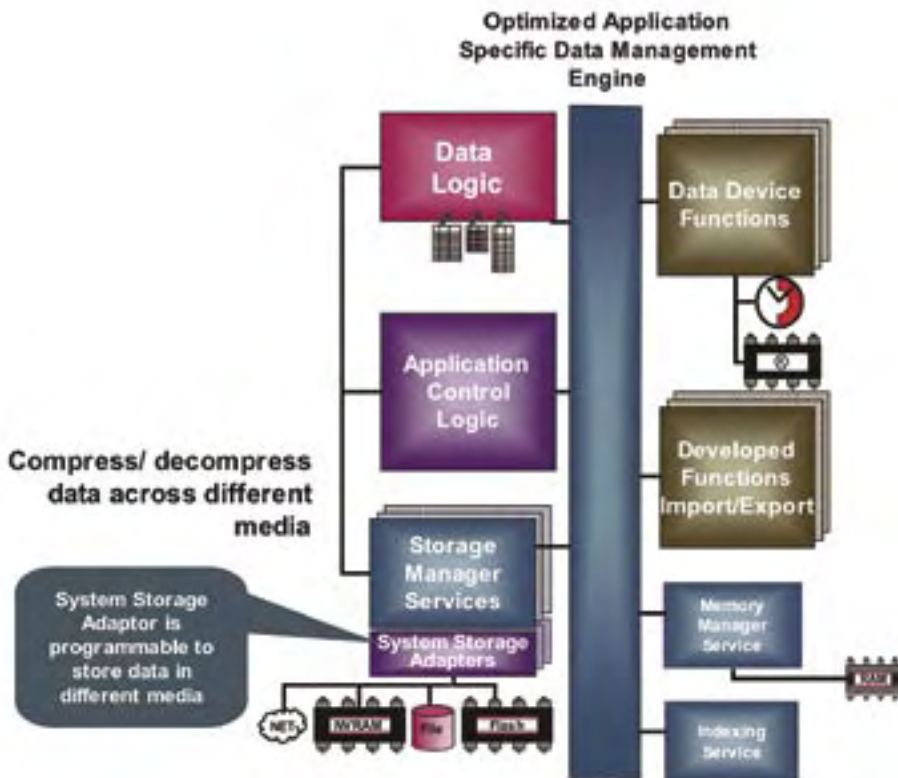

Figure 2



The Preferred Supplier for 3U CompactPCI

Savings-Box

- Open Standard 3U cPCI
- Rugged 19" Construction
- The IPC Alternative
- From \$1700.0



Pentium M Celeron M

- 600 MHz to 2.0 GHz
- Opt. -40°C to +85°C
- From \$1100.0

RSC #45 @ www.embedded-computing.com/rsc

Inova Computers, Inc.
 18275 North 59th Avenue
 Suite 152
 Glendale, Arizona 85308
 Tel.: 602-863-0726
 Fax: 602-863-0796
www.inova-computers.com



of descriptors that match the current location, and for the locations of the most suitable restaurants and parking places near Grand Central train station.

When the driver makes a selection, the voice recognition subsystem parses the input and selects one of the descriptors that correspond to the restaurant choice. This descriptor is then passed to the navigation subsystem, which will request detailed location information from the VASD component so that it can construct a detailed route plan. Each instruction will be sent by the navigation subsystem to the text-to-speech component to guide the driver.

Data management services

One common theme of the transactions in this distributed system is that there are a number of data transactions involved, some involving queries across distributed subsystems. Others involve the relay of results from those queries.

Such a system can be programmed using standard C/C++ function calls in the traditional embedded development model. In most embedded applications up to now, developers have had to laboriously design and implement their own custom data management code to handle a variety of jobs including message parsing, data lookups, and building descriptor tables.

Relational data model

Such ad hoc programming techniques were in common use in the enterprise-development model up to the 1970s. However, with the development of relational data management theory during the 1970s, developers quickly moved to embrace standardized methods of managing data.

The relational data model stores information in the form of linked tables. Rather than using traditional data structures such as pointers and linked lists to provide the connections between records in different tables, the references are to index locations. Indexes managed by the relational database management system handle the retrieval of data from the various tables. This makes it possible for a simple data structure – a two-dimensional table – to model arbitrarily complex information structures in a consistent way.

Structured Query Language

A further advantage of the relational data management system is that it makes use of a highly optimized language to make it easy for programmers to write data retrieval code. By far, the most commonly used data management language in use today is the Structured Query Language (SQL). In fact, SQL is the lingua franca of enterprise-level data management.

Using traditional embedded development techniques, the programming team has to build its own indexing and search algorithms. Although the B-tree index structures used by many data management systems are well understood, this process involves unnecessary reinvention and reimplementations of code that has been written hundreds of times by different teams in the past.

The developers of SQL decided that knowledge of B-tree structured indexes and table management was not useful to the programmer and simply made the job of writing applications more difficult. They therefore made SQL a declarative language. Instead of describing in detail the procedures the database management system should use to find and retrieve data, SQL simply asks that the programmer provide the type of information to be retrieved. The database engine parses the request made using SQL and then decides how best to retrieve the data.

For data-retrieval code, the use of SQL can greatly reduce the amount of time needed to program a data-retrieval request. According to research performed by Software Productivity Research (SPR), languages differ in their expressiveness as they move up the levels of abstraction.

This can be measured in the number of statements it takes to code one function point, a common measure of programming productivity. The higher the level of a language, the fewer lines of code that it takes to write a function point. According to SPR, if you take basic assembly language as occupying level 1, C is a level 2.5 language that needs 128 statements to construct a function point. At that level, a developer could be expected to code between five and ten function points in a month.

SYSTEM MANAGEMENT MADE EASY

Monitor, Control, and Ensure operations with our
Chassis and Shelf Management Solutions.
AdvancedTCA, CompactTCA, and CompactPCI

CARLO GAVAZZI
COMPUTING SOLUTIONS

Get Well Connected | 800.926.8722 | www.gavazzi-computing.com

RSC #46 @ www.embedded-computing.com/rsc

ICS daqPC

Record 70 MHz
IF Signals with
Bandwidths
Up to 40 MHz

A 'Record Breaking' Data Recorder that
Acquires and Records Acoustic/Radio
Signals at **400 MBytes/s**

Over 1.4
Terabyte
Internal
RAID

Analog I/O
(Acoustic/Radio Signals)

GPS/IRIG-B
Digital I/O

Dual
1 Gbit
Ethernet

1.4 TByte
Internal RAID
(Removable
Drives)



8.7"

19"

This
has been
changed
"/s" added

Record a
large number
of Acoustic
Signals
(24-Bit)

NTFS File
System

Dual Gbit
Ethernet

From
Under \$50K

The Amazing DaqPC:

- Customized to your requirement
- Record / Playback Multi-Channel Acoustic Signals with up to 24-Bit Precision and Sample Rates up to 2.5 MHz
- Record / Playback Radio Signals with 14-Bit Precision and Sample Rates up to 100 MHz
- GPS / IRIG-B Synchronized Sampling and Data Time Stamping
- NTFS File System
- Over 1.4 Terabyte RAID Storage
- Dual 1 Gbit Ethernet
- Data Integrity Check while Recording Via Time and FFT Snap Shots

For more information, download Application Note AN-DD-1 from our website at www.ics-ltd.com

RSC #47 @ www.embedded-computing.com/rsc



ICS

SENSOR PROCESSING

(613) 749-9241 TEL
1-800-267-9794 USA
(613) 749-9461 FAX
sales@ics-ltd.com EMAIL
www.ics-ltd.com

Engineered Solutions for Embedded Systems

Featuring:

TMZ104

Low Power CPU Module



- Transmeta Crusoe TM5500 CPU processor running from 333 to 533MHz
- x86 code morphing software provides
- LongRun advanced power management
- Full feature I/O

IR104

Industrial Relay Board



- PC/104 Compliant
- 20 optoisolated input and 20 output relays
- Output rating 5amp @ 250V AC or 30V DC
- 3V to 24V AC or DC input
- I/O mapped

HE104-DX

60W PC/104 Power Supply



- 60 Watt power supply
- 6V to 40V DC input range
- +5V, +12V, -5V, and -12V DC output
- PC/104 compliant
- Extended temperature: -40°C to +85°C

Contact Tri-M Systems for more information:
www.Tri-M.com info@Tri-M.com

1.800.665.5600

Tel: 604.945.9565 Fax: 604.945.9566

RSC #48 @ www.embedded-computing.com/rsc



In SPR's analysis, SQL is a level 25 language: it is much more expressive than C for data management applications. Rather than require over 100 statements to code a function point, it needs just six, which allows developers to write more than 30 function points in a month. Instead of writing code to parse the request from the speech-processing subsystem described above, the queries can be readily converted to SQL using simple string-processing functions such as shown in Figure 3.

```
Location "name=?" "address=?" "type=restaurant" "attribute=Italian"  
=>  
SELECT name, address FROM Tables.Location  
WHERE type = 'restaurant' AND attribute = 'italian';
```

Figure 3

Simplified development

By hiding much of the complexity of data management from the application programmer, a relational data management system can provide several features that ease development. One feature is that developers can treat the application's data atomically, because the underlying services maintain complete data integrity, regardless of the machine state. In addition, data management systems provide for the durability of data across transactions and system exceptions by making use of built-in facilities for rollback, recovery, and persistent storage.

A further advantage of using a data-centric approach allowed by a SQL-based data management system is that this structure is suited to distributed systems, such as the architecture used for automotive telematics. A programmer can use a simple API to send a SQL request to another node on the network and receive a simple table of descriptors as the reply. What could require tens of function calls to invoke network services using a traditional approach, can be brought down to one or two calls.

Optimized embedded data management

Despite the known benefits, few embedded projects have made use of a data-centric approach to development. This is because the back-end data management engines written for the enterprise environment are large, reducing the amount of space that can be used to hold data in an embedded system. However, much of this bulkiness is due to the requirements of the enterprise environment.

A data management engine for the enterprise environment is expected to support all of the features of SQL, whether they are ever used by an application or not. SQL has many constructs that are never used, even in some large-scale applications. As a result, it does not make sense to transfer a desktop database system to the embedded environment. Instead, it is possible to take the best elements of an enterprise data management system and create an embedded data management architecture that greatly eases development without incurring an overhead and is optimized for resource constrained environments like most embedded systems.

In the embedded environment, it is possible to strip out functions that are not used by an application at compile time. Furthermore, there is no need to pass SQL queries as such at runtime. They can be compiled after development to an intermediate, pre-parsed form, differing only in the actual data requests. For example, replacing "restaurant" with "supermarket," or changing the type of restaurant from "Italian" to "Chinese." These techniques can greatly reduce the runtime overhead without losing the expressiveness of SQL-based development for the data-centric parts of the application.

Lock manager

Another source of overhead in enterprise engines is the lock manager, used to protect the integrity of the data from corruption that may be caused by two applications trying to change the same piece of data independently. Application developers in embedded environments typically require tight control over concurrency issues, so they are quite

accustomed to managing the concurrency details that are left to the operating system in other environments. This makes a data manager more of a luxury than a necessity. However, the overhead involved in spawning operating system constructs to provide data integrity quickly consume precious resources – most notably memory and processor time.

The absence of a lock manager greatly expands the applicability of a data management engine to far less expensive microprocessors and simpler operating environments than would otherwise be possible. The lack of a lock manager does mean that access to the data is single threaded, so designs that involve long-running queries should be designed with care. However, this sort of query is rare in most embedded systems. In the telematics system, the queries will rarely fetch more than a few records and the information held by the VASD component will rarely change.

“A more efficient mechanism for crash recovery in the embedded space is to ensure that updates are not made to data in-place before a transaction is committed.”

Transaction log

Another feature of an enterprise data management engine is the transaction log. A transaction log is a change-list that is designed to be used with the main database to assure consistency. Although it is needed for enterprise-level, online transaction-processing applications, the transaction log is an expensive burden that an embedded system is better off without. A more efficient mechanism for crash recovery in the embedded space is to ensure that updates are not made to data in-place before a transaction is committed. *Dirty bits* are used to mark records where an update has started but not completed, allowing the database engine to roll back failed transactions after crash recovery.

A benefit of not using a transaction log is that system initialization, even when recovery is needed, is far faster than the delta-list traversal needed to synchronize the main database with a transaction log. It is possible to open the data structures afresh every time it is accessed, in order to minimize battery use in a low-power device by shutting down RAM when it is not needed. This type of design would not be possible with a transaction log.

System implementation: Choices and flexibility

Having decided to use a data-centric approach to development that makes use of data management services, how would the telematics application be constructed?

The VASD component can store a postal code or a longitude-latitude pair for each location. In general, a longitude-latitude pair will be more difficult to search against because the coordinates must be stored as floating-point numbers. This will increase the index's size and complexity. However, the coordinates can be used to accurately confirm position to the navigation subsystem. One option is to split the longitude and latitude into mantissa and integer portions, using the index to search for just the integer portion of each.

THE COMPLETE DEVELOPMENT SOLUTION

Now offering GNU X-Tools and Linux support for a complete development solution. Call us today!

Arium offers robust JTAG emulation and development tools for today's software and firmware developers using targets with ARM7[®]/ARM9[®], Intel XScale[®], and TI OMAP[®] cores and Intel[®] Pentium[®] and Itanium[®] processor families.

- Real time, integrated ETM trace with up to 60 M virtual samples using Arium patent-pending compression technology.
- Highly integrated SourcePoint[™] IDE with powerful, flexible code editing with debug integration.
- Real time performance analysis for faster, more accurate results.
- Easy-to-configure ETM parameters, including 10 ns time stamp, for powerful, complex breakpoints and rapid data analysis.
- Fast, easy, intuitive run control with robust C-like command language facilities.
- Unparalleled customer support with highly experienced design engineers, WebEx[™] sessions, and Web site downloads and information.

It's hard to compete without the right tools!

American Arium • 14811 Myford Road • Tustin, CA 92780 • 877.508.3970 • www.arium.com

RSC #49 @ www.embedded-computing.com/rsc



The alternative is to use the postal code as the search criterion. Postal codes have been proven to be an effective way of organizing information for locations. Postal codes can be sorted into region tables that are loaded on-demand from disk into memory, lowering the storage overhead on the VASD subsystem. The relevant table would be loaded based on the postal code of the current location or that of a landmark, such as Grand Central train station.

The decision over which access method to use will depend on the amount of online storage that the VASD subsystem has at its disposal and the additional processing needed to work with data that is segmented by the postal code. The system may have to scan several postal code zones if the destination is close to the boundary of one of the zones, which will increase processing time. The situation is further complicated by the nature of most postal code systems: postal code zones often have an irregular shape. Heuristics will be needed to determine how far a search should extend into neighboring zones. The use of longitude and latitude data for the index into the database may increase overall processing load but simplify the implementation of the VASD search function because the data can be divided using a regular grid.

Having received the request from the speech-recognition subsystem, the VASD component performs the query and retrieves a set of restaurants together with their postal codes and coordinates. These coordinates would be used to calculate relative distances from the main landmark of Grand Central train station and the nearest parking places. This distance information would be passed with other details in the form of a table of descriptors to the text-to-speech system. Once the driver has made the final selection, the speech-recognition system would query the VASD for details on the restaurant that can be passed on to the navigation subsystem. That subsystem interrogates its own database to generate a route to the destination.

Stored functions

A further optimization for embedded systems is the use of stored functions to manipulate data on behalf of subsystems, such as calculating the distance between two coordinates. This will be a commonly required service and its implementation as part of the database engine greatly eases application development for other parts

of the telematics system. For example, in the VASD system, stored functions can be used to calculate distance information on behalf of the speech and navigation subsystems, presenting the distances calculated as though they were just fields stored by the data management system operating within the VASD. With stored functions, the clients can treat all calculated values as being part of the database itself; they do not need to be concerned with the fact that they are derived values (Figure 2, page 45).

Dynamic decompression

As storage space is often limited in the embedded environment, an additional feature that could be deployed is dynamic decompression of the geographic data. Embedded data management systems can include support for media that can store data in compressed form, decompressing the information on the fly as it is needed (Figure 2). The use of compressed data will be transparent to the programmers, as the tables would be decompressed on the fly as they were read in from non-volatile memory or disk either as postal codes or as blocks based on longitude and latitude.

**“Embedded data management systems
can include support for media that can store data
in compressed form, decompressing the information
on the fly as it is needed.”**

Developers would make use of declarative SQL-style requests similar to those illustrated in Figure 3, fetching both regular data fields and those calculated using stored functions. Using SQL as the basis for the data management code, developers can rapidly prototype different approaches to using the geographic data. Compilation would convert what the programmer sees as a set of regular SQL commands into more efficient code that provides both communication between the subsystems and the necessary data management code. Because the data-access code has been greatly simplified, it is straightforward to alter the system and try out different approaches to storage and retrieval to come up with an optimum solution for the VASD and other subsystems.

Summary

Using a data-centric approach to development that leverages standards-based data management engines, it is possible to greatly simplify the construction of complex distributed, data-centric applications such as those needed for future generations of automotive telematics systems. Optimizations are possible that reduce the burden of using standard, high-level languages such as SQL to build these applications that fit the concurrency models and hardware resource constraints encountered in embedded systems. As a result, the benefits that enterprise developers have had for many years can be brought to the increasingly complex embedded world. **ECD**

Eugene Buechele has succeeded in key technical and business development positions throughout his 30 plus year career in computer software and systems. Most recently, Buechele was the Vice President Engineering and Chief Technology Officer at Ten Square, innovating in the interactive point of sale broadcasting and publishing industry. He has held senior executive positions overseeing the development of Embedded Systems at HP, Verifone, 3Com, Communications Solutions, Inc., and Intel. He holds a Bachelor degree in Philosophy/Mathematics from Wright State University.



For more information, contact Eugene at:

ENCIRQ Corporation
577 Airport Blvd, Suite 7900
Burlingame, CA 94010
Tel: 650-292-3535 • Fax: 650-292-3536
E-mail: eugene.buechele@encirq.com
Website: www.encirq.com



Off-the-shelf XScale[®] based single board computers and industrial wireless solutions...

Cellular Wireless/GPS

- Wireless embedded baseboard to support low power PC/104 CPU boards
- Wireless cellular modem fitting options:
 - Motorola i01500R (iDEN)
 - Sony Ericsson GM47/48 (GPRS)
 - Siemens MC35i (GPRS)
- GPS module - Trimble LassenSQ
- Wide input PSU: 10 - 30V DC

Get to market faster with Arcom's ready-to-run, modular hardware for GPRS, iDEN and GPS wireless solutions...

MERCURY

- 533MHz Intel[®] IXP425 comms processor
- 2 x 100baseTx Ethernet ports
- 4 x USB 2.0 and 4 x serial ports
- 64Mbytes DRAM / 32Mbytes Flash
- CompactFlash (CF+) and PC/104 bus

VIPER

- 400MHz Intel[®] PXA255 processor
- Ultra-low power 1.9W (typical)
- 64Mbytes DRAM / 32Mbytes Flash
- Ethernet, USB and 5 x serial ports
- CompactFlash (CF+) and PC/104 bus

www.arcom.com

Development Kits

Embedded Boards

PCs & Enclosures

Industrial Networking

Design & Build

Arcom

us-sales@arcom.com
888-941-2224

Think Embedded.
Think Arcom.

SHAKE, RATTLE AND **ROLL ON.**



RUGGED, MISSION-CRITICAL COMPUTERS

PROCESSOR PLATFORMS

SUN®

IBM®

INTEL®

OPERATING SYSTEMS

SOLARIS®

LINUX®

WINDOWS®

When it comes to extreme operating conditions, nobody keeps mission-critical applications rolling like Themis Computer.

For over a decade, Themis has delivered high performance, high availability computing for the harshest, most demanding applications and operating environments.

Designed to perform in conditions where other systems fail, our unique thermal and mechanical technology continues to set the standard for rugged, mission-critical computing – up to 40G shock.

Themis' family of UltraSPARC VME and Compact PCI single board computers

and graphic accelerators are the latest demonstration of our design expertise, offering ruggedized computers with the fastest, widest range of performance options. Unlike others, our rugged VMEbus computers provide more scalability, far greater reliability, improved life cycle management and substantially lower TCO.

So when your data is critical and the environment is hostile, turn to the computers built to perform when there's a whole lot of shaking going on.

Themis rugged, mission-critical computers. Designed to take it.

Copyright 2005, Themis Computer. Themis, Themis logo, TA64, and TGA3D+ are trademarks or registered trademarks of Themis Computer. All other trademarks contained within are property of their respective owners.

USP III™ VMEbus COMPUTER

Industry's highest performance VME engine
Single/Dual UltraSPARC® III 64-bit processors
3-way SMP 64-bit Solaris™ 8 and 9 support
Ruggedized for up to 40G shock



NEW! TA64™ 64-bit VME COMPUTER

Low Power, AMD Mobile Athlon™ processor
Single/2-slot VME configurations
Up to 4GB ECC DDR memory, 4 PMC slots
Compatible with USBle-USB SBCs
64-bit Solaris™ 10, Windows®
and Linux® support
Ruggedized for up to 30G shock



TGA3D+™ GRAPHICS ADAPTER

USB/USBle-Gb 3-D graphics accelerator
Provides Sun® XVR-500 3-D graphics support
8.5M triangles/sec, 160M textured pixels/sec
Solaris 8 and 9 support
Sun OpenGL for Solaris 1.2.1 and later



THEMIS COMPUTER

3185 Laurelview Court
Fremont, CA 94538
510-252-0870

THEMIS COMPUTER EUROPE

5 rue Irene Joliot-Curie
38320 Eybens, France
+33.476.14.77.86



THEMIS
COMPUTER

WWW.THEMIS.COM

Building access media gateway solutions with media gateway modules

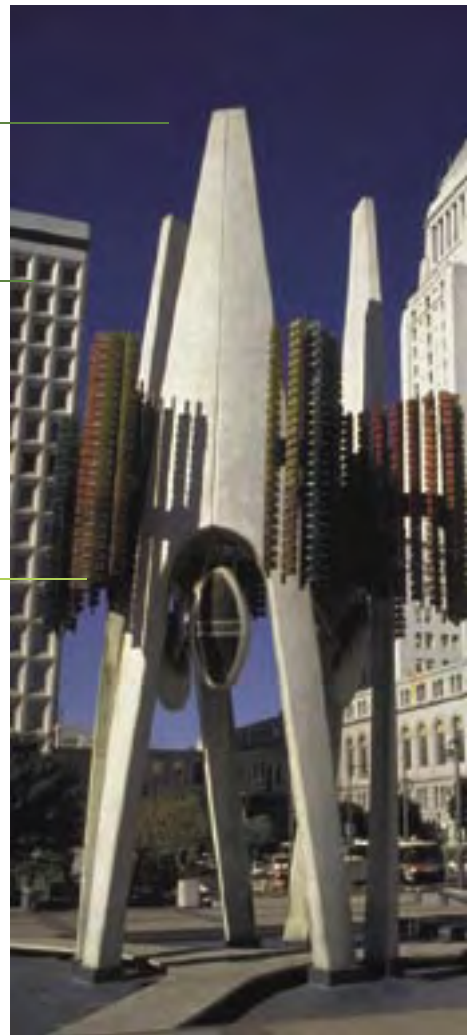

By Tim Resker

One of the more notable developments in the residential voice services market is the emergence of VoIP-based voice services from multiple system operators such as Comcast, Cox, and Time Warner Cable. Also significant is the growing number of pure-play VoIP service providers such as Vonage, SunRocket, and Skype.

These services require the deployment of access media gateways that support a specific set of requirements for Class 5 or Class 5 replacement access networks. The use of a standards-based media gateway module allows media gateway manufacturers to utilize a functionally complete and thoroughly tested media gateway subsystem in the development of their media gateway products. In this article, Tim describes the functionality of a standards-based media gateway module.

Media gateway call flows

From a pure capacity standpoint, media gateways that serve a residential access network must support a calculated call flow determined through an Erlang calculation. This calculation takes into account factors such as the Busy Hour Call Rate, call duration, and on-net call percentage.

The results translate directly into subsystem port density requirements that range from 672 ports (DS3 at 45 Mbps) to 2016 ports (OC3 at 155.52 Mbps). The Performance Technologies MTN4300 media gateway module scales very nicely in this port density range (Figure 1).

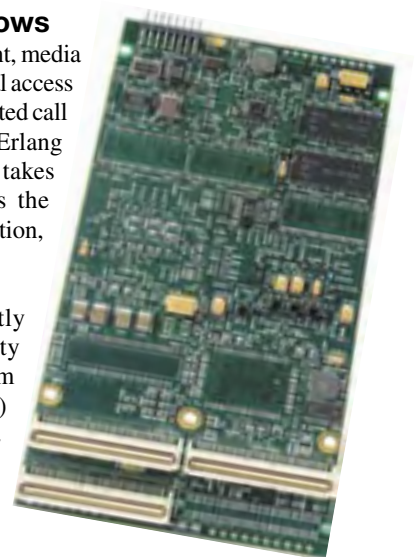

Figure 1

Performance Technologies also offers the following media gateway modules:

- The MTN4302, which adheres to the PTMC option 2 pinout specification, supports vocoder (voice encoder) port densities up to 1008 ports using the G.711 encoding scheme. The module also supports low bit-rate vocoders at lower densities.
- The MTN4305, which adheres to the PTMC option 5 pinout specification, supports a range of vocoder port densities up to 2016 ports of G.711. This module also supports low bit-rate vocoders at lower densities.

Form factor support

The Performance Technologies MTN4300 media gateway module complies with the PCI Mezzanine Card (PMC) format and supports the PICMG 2.15 PTMC option 2 and option 5 standard pinouts. This allows the MTN4300 to be used in conjunction with CompactPCI carrier card solutions from either Performance Technologies or third-party vendors.

Call control protocols

Media gateway subsystems for access networks must support the MGCP or H.248 Megaco call control protocol to enable their operation within a softswitched VoIP network. Legacy features

of the Class 5 switch and its associated services must also be supported. This includes features and capabilities such as call progress, caller identification, and voicemail.

An ideal media gateway module would both generate and detect call progress tones including special information tones, ringback tones, busy tones, and reorder tones. Additionally, generic tone detection and generation support allow for the support of international call progress tone variants.

"...nearly all voice services provide a voice-driven user interface that utilizes basic voice record and playout functions..."

Voice messaging

Voice messaging services represent a tremendous revenue opportunity for VoIP service providers. Voicemail is the most ubiquitous voice messaging application. However, nearly all voice services provide a voice-driven user interface that utilizes basic voice record and playout functions combined with either DTMF-based commands, or the now more common speech recognition commands.

The MTN4300 offers a call conferencing feature that supports conferences with up to 64 participants with dynamic add/drop capabilities, and it also provides several methods for voice record and playout with each method geared toward a specific type of messaging application.

CALEA compliance

The Communications Assistance for Law Enforcement Act (CALEA) defines the obligation of telecommunications carriers to assist law enforcement in executing electronic surveillance (traditionally known as wire tapping). The act requires

PC/104 Analog, Digital, Relay and Serial I/O Boards

Products from **ACCESS I/O**

PC/104
PCI BOARDS
ANALOG & DIGITAL I/O BOARDS
BUS EXPANSION KITS
ISOLATED INPUT/RELAY OUTPUT
WATCHDOG TIMERS
SERIAL COMMUNICATIONS
DISTRIBUTED I/O

- Multi-function 12 and 16-bit analog I/O including high density signal conditioning
- Digital I/O up to 48 bits including models with change of state detection!
- 8 and 16-channel digital input/relay output boards
- Optically isolated and multi-port RS-232/422/485 serial communications

ACCESS I/O PRODUCTS, INC.
10623 Roselle St., San Diego, CA 92121
Fax: 858-550-7322
email: sales@accessio.com
800-326-1649
www.accessio.com

Now available from ACCESS I/O

Complete, integrated embedded systems
We'll build *your* system on *our* foundation!

ACCESS I/O. Solid. Reliable.
Acquisition Control Communication Engineering / Systems

RSC #54 @ www.embedded-computing.com/rsc

carriers to design or modify their systems to ensure that lawfully authorized electronic surveillance can be performed.

Access media gateways must support the ability for a voice services provider to meet the requirements of CALEA. There are several means by which this can be accomplished. The most common is through a simple conferencing function where the media gateway mixes the participants input and delivers a mixed voice stream, called a combined call content channel, to a law enforcement collection server.

The MTN4300 also supports an alternative method that delivers separate streams for each call participant across separate call content channels to a law enforcement collection server.

VoIP security

Security is another service that has been closely examined by VoIP service providers. First, as a means to protect their own network from denial of service attacks, call interception, signal protocol tampering, toll fraud, and presence threat. Secondly to provide revenue-producing services to businesses and government agencies that require secure voice services.

The MTN4300 fully supports IPsec and SSL type VPN processing in hardware, with direct support for DES, 3DES, AES, ARC4, SHA1, and MD5. In addition, a true entropy-based random number generator is implemented in hardware. This security and authentication capability can be applied to both media streams and signaling.

Network convergence

Media gateways play a key role in the convergence of voice and data networks that promise to deliver new, improved, and less expensive voice communication services. While all media gateways perform the same basic function of processing voice streams between TDM and IP networks, differing network environments and voice services determine the exact requirements of each particular media gateway application.

As such, many different applications of the media gateway exist, including the access media gateway. A standards-based media gateway module allows OEMs to bring many different media gateway applications to market faster and with less development cost and risk. **ECD**

Tim Resker is a Senior Product Manager with the Voice Technology Group of Performance Technologies. He received his BS in Computer Science from Northeastern University and an MBA from Babson College.



For more information, contact Tim at:

Performance Technologies
 315 Norwood Park South • Norwood, MA 02062
 Tel: 781-751-2400 • Fax: 781-751-2470
 E-mail: tresker@pt.com
 Website: www.pt.com

EMBEDDED PLANET™

design.

The next generation of Internet infrastructure.

develop.

Your products based on our platform.

deploy.

Your solution faster.

Embedded PowerPC / Xscale

Freescale 82xx, Intel 42x

Design your solution using our line of PICMG compliant PPMC modules and leverage the power of Freescale PowerPC 82xx and Intel Xscale 42x processors.

Develop prototypes using your preferred RTOS and the boot loader and diagnostics in our PlanetCore software.

Deploy our proven computing engines in your end product and meet your networking, industrial or military application requirements on time and within budget.

EP8280

PPMC / PTMC module
Easy access to CPU
SDRAM: 32, 64, 128 or 256MB
Flash: 16, 32 or 64MB
Two 10/100 Ethernet
Two RS232
JTAG

EP8245

PPMC module
Easy access to CPU
SDRAM: 32, 64, 128, 256MB
Flash: 8 or 16MB
One 10/100 Ethernet
One RS232 and JTAG
MiniPCI Type 3

EP425

PPMC / PTMC module
Easy access to CPU
SDRAM: 32, 64, 128 or 256MB
Flash: 16, 32 or 64MB
Two 10/100 Ethernet
Two RS232
USB and JTAG

We can customize any of our modules for your application. Visit our website or contact us today for your complete solution.

4760 Richmond Rd / Cleveland, OH 44128
Tel: 216.245.4180 / Fax: 216.245.4150
www.embeddedplanet.com

RSC #55 @ www.embedded-computing.com/rsc



Having the right tools is 90% of the Job.

Elma Bustronic's broad range of test accessories is designed to make a test engineer's life easier. For example, our VME64x Extender Board provides convenient out-of-chassis access so you can test your board quicker, safer and more productively. With several creative features, it has specially designed handles to hold the board to the extender more securely. The same innovative thinking goes into all our other test tools -- from Load Boards to Adapter Cards to System/Voltage Monitors, and more. And like most of our accessory products, they're available in VME, VME64x, VXI and CompactPCI architectures.

Elma Bustronic's wide selection of test accessories helps ensure your product offers maximum performance with minimum downtime.

ELMA BUSTRONIC

Make life easier. Call us today.

Tel: 510.490.7388 Fax: 510.490.1853 info@bustronic.com



Test Extender Boards



Load Boards



System/Voltage Monitors



Power Interface Boards

Blades

Blades

Company name Model number	Network processor	Processor	Server	Storage	Switch	Transition	Website
ACT/Technico							www.acttechnico.com
RaidStor	•						
ADLINK Technology							www.adlinktech.com
cPCIS-3100BLS			•				
Adtron							www.adtron.com
IC6C				•			
IC6HB				•			
AMTelco							www.amtelco.com
XDS MC-3 Boards	•						
Annapolis Micro Systems							www.annapmicro.com
WILDSTAR II Pro for PCI		•					
WILDSTAR II Pro for VME		•					
Apcon							www.apcon.com
Intellapatch 16					•		
Artesyn Communication							www.artesyncp.com
Katana 3750		•					
Katana 750i		•					
Katana750v	•						
KatanaPPB		•					
KatanaQp		•					
SpiderWareSG		•					
SpiderWareSS7		•					
Concurrent Technologies							www.gocct.com
High Performance SBC		•					
Continuous Computing							www.ccpu.com
cPCI Blade Solutions		•					
Diversified Technology							www.dtims.com
cPB-4305		•					
cPB-4321		•					
cPB-4610		•					
cPC-4325		•					
HMP Platform	•						
DSS Networks							www.dssnetworks.com
Metro-Switch Model 8261					•		
Extreme Engineering							www.xes-inc.com
XCalibur1000		•					

Company name Model number	Network processor	Processor	Server	Storage	Switch	Transition	Website
Fulcrum9							www.fulcrum9.com
ATCA TX/RX BENCHBLADE						•	
ATCA TX/RX SIGNALBLADE						•	
GE Fanuc Automation							www.gefanuc.com/embedded
CP721		•					
Interactive Circuits & Sys.							www.ics-ltd.com
PCI Software Radio Memory Blade				•			
PCI Software Radio PowerPC DSP Blade		•					
PCI Software Radio TI C64 DSP Blade		•					
PCI Software Radio XILINX FPGA Blade		•					
Interphase							www.interphase.com
iNAV Series	•						
Motorola							www.motorola.com/computers
CPIP5365	•						
Performance Technologies							www.pt.com
CPC5505 SBC		•					
CPC5702		•					
Pinnacle Data Systems							www.pinnacle.com
BlueSwitch-650			•				
RadiSys Corp							www.radisys.com
EPC-3311		•					
EPC-3412		•					
Promentum ATCA-2100					•		
Promentum ATCA-4000		•					
SBS Technologies							www.sbs.com
HDTBlade		•					
VR-9 6U VMEbus SBC		•					
SKY Computers							www.skycomputers.com
SMART SMP Compute Blade		•					
SSV Software Systems							www.ssv-embedded.de
Low Cost DIL/NetPC	•						
Sun Microsystems							www.sun.com
Netra cp2300			•				
Voiceboard							www.voiceboard.com
TDM to Packet Processor	•						

Company name Model number	Description/Website
Anatel www.anatel.com	
TAP-804N	An open, DSP-based, PCI telephony resource board that delivers a full trunk's worth of audio compression (up to 30 channels) • Thirteen 60 MHz TMS320C32 floating point processors provide a maximum 780 MFLOPS of compute power • Supports the Multi-Vendor Interface Protocol (MVIP) and Signal Computing System Architecture (SCSA) standard TDM data buses • 128 local TDM data channels • 4 MB of global DRAM • 512 KB of local SRAM per DSP • SPOX RTOS • Driver support for UNIX and WindowsNT • 10/100Base-T Ethernet connection • A software developers kit includes libraries, sample programs, and debug, load, and other utilities • Voice compression, fax/data/modem, and DSDV algorithms can be developed with Analogic's debug tools, serial port, and software
TAP-806	A PCI-based DSP resource board designed for PSTN-to-VoIP connectivity applications • Up to twelve 100 MHz TMS320C549 DSPs deliver 1200 MIPS performance • Specified for 60 channels of G.723.1 and G.729 voice compression, FAX, and data modem standard and proprietary algorithms • Dual T1/E1 interface • 10/100Base-T Ethernet • H.100 telephony bus • 512 local TDM data channels • Switch 256 of 4096 H.100 channels to local channels • 64 MB of global DRAM • 512 KB local SRAM per DSP • Driver support for Solaris, UNIX, and WindowsNT
TAP-810	CompactPCI-based DSP resource card designed for PSTN-to-VoIP connectivity applications • Specified for 120 channels of G.723.1 and G.729a as well as other standard and proprietary algorithms, the board features quad T1/E1 line interfaces and a 100Base-T controller • Integrating all these resources onto a single CompactPCI board allows voice and data entering the T1/E1 interface to be compressed by the DSP resource and exit through the Ethernet interface without unnecessary processing by the host or bandwidth transfers over the bus • Hot swap-compliant, connections are made through the real-panel I/O transition module
Atmel www.atmel.com	
AT76C901	A VoIP chip for Wi-Fi-based phones • Capable of running VoIP software, firmware enabling 802.11b (Wi-Fi), and voice compression and decompression on a single chip • Consists of an ARM7TDMI RISC processor for running VoIP protocol stacks, a subsystem with an ARM7 and 802.11b MAC, and another subsystem with an OakDSPCore and integrated voice codec • OAK performs voice compression and decompression to the ITU standards such as G.711, G.723.1, and G.729ab • Runs the VxWorks RTOS • Packaged in a 217-pin uPGA package
AudioCodes www.audiocodes.com	
ATP-1610	A 16 E1/T1, CompactPCI, PSTN media processing board • Up to 480 IVR streaming ports • Up to 240 universal media processing ports • Comprehensive IVR control • Voice record/playback • Real-time, multi-party conferencing • Speech-enabled application support • Fax termination/generation (T.37) • Interchangeable PSTN or TDM endpoints • PICMG 2.16-compliant cPSB Ethernet on the backplane • Integrated, software-controlled E1/T1 interfaces • Voice compression on a per-channel basis • VoIP packet streaming (RTP/RTCP) per RFC 1889/1890 • MGCP, MEGACO, SIP, and AudioCodes' proprietary TPNCIP
ATP-260	A four E1/T1, PCI media processing board • Up to 120 universal media processing ports • Comprehensive IVR control • Voice record/playback • Real-time, multi-party conferencing • Speech-enabled application support • Fax termination/generation (T.37) • Interchangeable PSTN or TDM endpoints • MVIP, SCbus, and H.100 CT bus interface support • Integrated, software-controlled E1/T1 interfaces • Voice compression on a per-channel basis • VoIP packet streaming (RTP/RTCP) per RFC 1889/1890 • MGCP, MEGACO, SIP, and AudioCodes' proprietary TPNCIP • Universal PCI version
IPM-1610	Up to 480 IVR streaming ports • Up to 240 Universal media processing ports • Voice Record/Playback • Interchangeable RTP or PSTN or H.110 endpoints • Real-time, multi-party conferencing • Comprehensive IVR control • VoIP packet streaming (RTP/RTCP) per RFC 1889/1890 • MGCP, MEGACO, SIP and AudioCodes proprietary TPNCIP • cPSB PICMG 2.16 compliant Ethernet on the backplane • Automatic Speech Recognition (ASR)
IPM-260	IP-enabled, cost-effective technology • Field-proven PSTN interface board • Low to high channel density • Independent call-by-call basis LBR ports • All-in-one integrated board • Shorter development cycle • 240 universal ports supporting voice, fax and data • Various voice compression includes G.711, G.723.1, G.729A • Voice Record/Playback • Real-time, multi-party conferencing • Interchangeable RTP or PSTN or TDM endpoints • Comprehensive IVR control • VoIP packet streaming (RTP/RTCP) per RFC 1889/1890 • MVIP, SCbus and H.100 CT bus interface support • Automatic Speech Recognition (ASR) • Text To Speech (TTS) • Optional Universal PCI Version
MGCP	A Media Gateway Control Protocol (MGCP) • Portable C language software application library running on top of AudioCodes' VoicePacketizer stack • MGCP client stack supports the IETF MGCP protocol and can be controlled by any IETF compliant call agent • Client stack typically runs on the master communication processor of a VoIP gateway, access multiplexer, or other packet network access or switching equipment • Assumes a call control architecture where the call control intelligence is outside the media gateway and handled by an external call agent • A master/slave protocol, where the gateway is expected to execute commands sent by the call agent • MGCP client stack provides the means for communicating with a call control entity, while isolating the lower levels of implementation
MP-104	An analog VoIP gateway subsystem • Supports four analog ports • Internal power supply with option for -48V input • 10/100Base-Tx Ethernet port and option for second 10Base-T port • Long-haul and short-haul support • Life line support • Message waiting indication • Metering tones • Polarity reversal • 3-way calling option
MP-108	An analog VoIP gateway subsystem • Eight analog ports • Supports PSTN/PBX or telephone lines • Connection to the IP network through 10/100Base-Tx Ethernet interface • Selectable coders per channel include G.711, G.723.1, G.726, G.729A, GSM 6.10, and NetCoder • T38 compliant, tolerant to network delays of up to ten seconds (round trip) • Complies with AudioCodes MGCP, H.323, Megaco (H.248), and SIP protocols • Manageable through SNMP and WEB browser • 1U-height half-shelf 19-inch enclosure
SB-1610	Multiple capacity options up to 480 or 240 voice independent cellular and VoP channels • Complete Media Gateway on a CompactPCI Board • Standards compliant cellular and VoP vocoders • Standard control: MGCP (RFC 2705), MEGACO (H.248) • Real-time Fax over IP/T.38 • On-board announcement support towards PSTN/TDM and IP • Tone detection and generation (MF, DTMF, RFC 2833) • PSTN Signaling: CAS, ISDN PRI, and SS7 • SIGTRAN M2UA and IUA over SCTP • cPSB PICMG 2.16 compliant Ethernet on the backplane

Company name Model number	Description/Website
AudioCodes (continued) www.audiocodes.com	
TP-12610	A PICMG 3.0 compliant, AdvancedTCA media gateway board • High channel density; scalable up to 2016 LBR VoIP channels • Integrated Automated Protection Switching (APS) OC-3/STM-1 for PSTN interface • MEGACO (H.248) compliant • Complete media gateway on a blade • G.168-2002 compliant echo cancellation • Real-time fax over IP/T.38 • PSTN Signaling: CAS, ISDN PRI, and SS7 layer 2 termination • Tone detection and generation (MF, DTMF, RFC 2833) • SIGTRAN IUA, M2UA, M3UA over SCTP • Dual redundant PICMG 3.0 base interface
TP-260	E1/T1 PCI VoIP Communication Board • Complete standalone SIP media gateway on a PCI board • Low to high channel density • Concurrent toll quality voice and fax support • Wide range of PSTN signaling protocols termination • Fast time-to-market • Very small footprint • 30, 60, 120, and 240 channels of independent, simultaneous VoIP calls supporting voice, fax, and data ports
TP-2810	672 voice/fax independent multiple LBR channels • Integrated T3 telephony interface • Standalone Media Gateway on a single blade mode • VoIP packet streaming (RTP/ RTCP) per RFC 1889/1890 • Standard control: MGCP (RFC 2705), MEGACO (H.248) • G.168 compliant echo cancellation • Real-time Fax over IP/T.38 • On-board announcement support towards PSTN/TDM and IP • Tone detection and generation (MF, DTMF, RFC 2833) • PSTN Signaling: CAS, ISDN PRI and SS7 • SIGTRAN IUA, M2UA, M3UA over SCTP • Dual, Redundant 100 Base-T interfaces, PICMG 2.16 compliant • High channel density • Concurrent toll quality voice and fax support • T3 PSTN interface • Carrier grade applications • Fast time-to-market • Flexible and easy migration to VoP networks • Extensive VoIP experience
TP-6310	7 2016 voice/fax independent multiple LBR channels • Integrated Automatic Protection Switching (APS) OC-3/STM-1 for PSTN interface • Standard control: MGCP, MEGACO • Complete media gateway on a blade • G.168 compliant echo cancellation • Real-time fax over IP/T.38 • PSTN Signaling: CAS, ISDN PRI and SS7 layer 3 termination • Tone detection and generation (MF, DTMF, RFC 2833) • SIGTRAN IUA, M2UA, M3UA over SCTP • Dual redundant 10/100/1000 Base-T interfaces, PICMG 2.16 compliant
VoicePacketizer	A Voice-over-IP streaming protocol stack • Portable C language software application library implementing RTP/RTCP encapsulation per RFC 1889/1840 • H.323 compliant and easy to integrate with the H.323 software stacks • Runs on the master communication processor of a VoIP gateway, access multiplexer, or other packet network access or switching equipment • Full duplex, real-time PCM voice or fax is compressed by the AC48xxxA-C and encoded by the VoicePacketizer into network-ready frames • Packets are transferred to the gateway master processor that adds the UDP/IP headers and sends them to the IP network • Packets received from the network are decoded by VoicePacketizer and fed into the AC48xxxA-C processor, decompressed, and output to the PCM interface • Dynamic jitter buffer built into VoicePacketizer automatically compensates for network delay variation in order to enable smooth real-time voice communication
DSS Networks www.dssnetworks.com	
GigaMAC PMC 5262-LC	A dual-port, high-performance, Gigabit Ethernet fiber controller card • Two fully independent 1000Base-X Gigabit Ethernet ports over single-mode or multi-mode fiber optics • Fully IEEE-802.3 compliant • Intel 82546 Gigabit Ethernet MAC/PHY/Serdes controller chip with onboard LC type fiber optic connectors • Onboard intelligent PCI-X DMA engine • Supports wire-speed 64-bit bus-master DMA operations utilizing maximum PCI/PCI-X bandwidth
GigMAC PCI-X 6267-SFP	4th Generation 82546 dual port MAC/PHY/Serdes chip from Intel • High performance wire speed, 484 MBps (3.8 Gbps) sustained raw throughput over 133/100/66 PCI-X • Up to 1,000,000 frames per second maximum transfer rate • PCI 2.2 Low-profile Card, 2.5 by 6.6 inches • VxWorks and Linux 2.4/2.6 driver support • Supports 1000-Base-X auto negotiation • Fully compliant to IEEE 802.3 1000 Base-X specifications • Low power: 3.5W @ 3.3V (board total) • 3 LEDs per port - Link, TX, and RX • 133/100/66 MHz - 32/64 bit PCI bus interface • 4th Generation 82546 dual MAC-PHY chip from Intel • Highly integrated, low chip count. Big or little endian. • Extended status and statistics
GAO Research www.gaoresearch.com	
VoIP 'C54x	A Voice over IP (VoIP) software package for the TMS320C54x • Can add voice, real-time fax, and data transmission capabilities such as long distance calling and/or faxing over the public Internet, managed networks, intranets, or virtual private networks • Available software modules include speech compression, telephony, V.34 modem, and V.17 fax
Iskratel www.iskratel.ru	
Calidia	A CompactPCI card for use as a standalone solution or building block • MPC8260 embedded PowerPC processor with 200, 266, or 300 MHz core • Up to 208 MHz RISC with more than 700 MBps aggregate throughput • Up to 128 Mbyte onboard SDRAM • Dual PCI bridge: 64-bit, 66 MHz CompactPCI I/F and 32-bit, 33 MHz local PCI • Flash memory: dedicated boot Flash and separate 4 Mbyte user Flash • Local TDM switch • 16 TI DSPs with StrongARM RISC support • Dedicated FPGA design connecting DSPs to MPC8260 • Dedicated CPM connection memory • Two quad E1 framers • Up to eight E1 links • Network connection via J5 using RTM • Hot swappable • System or non-system slot card • Digital PLL with holdover mode • CompactFlash mass storage • Two spare PMC slots • 16-bit UTOPIA Level 2 I/F ATM • PICMG 2.16 support • Dedicated 10/100Base-T Ethernet • RS-232 serial interface
ITOX www.itox.com	
Baby Cobra	Shoobox size PC for telephony and embedded applications • Small rugged industrial case, 15" Deep (76 x 178 x 381mm) • The CS15 motherboard supports Intel Pentium III and Celeron processors with front-side bus speeds to 133 MHz • Memory to 512 MB • Either one (SL model) or three Ethernet controllers (SN model) • GPIO • Onboard video • Watchdog timer • Thermal management • Two 3.5" internal drive bays: Both drive bays are available when a half-length PCI is installed • When using a full-length PCI card, only one bay is available • 130W external power supply provides 12VDC
Kallastra www.kallastra.com	
KeyTrunk500 Series	A set of high-density TDM and IP media processing boards • Capable of processing between 128 and 1,008 channels of TDM/IP traffic • Provides enhanced media processing features such as tone detection, playback, echo cancellation, and conferencing • Supports RTP streaming using standard RTP/UDP/IP/Ethernet protocol encapsulation • Provides a VoIP stack that includes ARP, ICMP, and RTCP functionality • Where trunking or multi-chassis interconnect is required, the KeyTrunk500 board also supports a specialized mode whereby multiple TDM streams are dynamically mapped into single RTP packets • On the network side, the board offers two 100Base-T Ethernet ports • On the TDM side, the board connects to the local PCM highways via a ribbon cable or backplane bus, and is compatible with H.100/H.110 industry standard TDM buses • For control, a 32-bit PCI interface is available that allows complete control of the board via an API

Continued on page 60

Company name Model number	Description/Website
Kane Computing www.kanecomputing.com	
Voice + Fax over IP	A voice and fax over IP DSP software solution • Provides core functionality for development of voice-over-packet applications • Software bundle with a unified interface, which integrates the DSP building blocks necessary for designing a complete VoIP solution • Integrates speech compression algorithms (G.723.1, G.729AB, G.711, and G.726) along with T.38 fax relay, echo cancellation (G.168-2000), UMTD, jitter buffer, VAD/CNG, tone rejection, and other configurable building blocks • Available as object codes for Texas Instruments' C54x, C54CST, and C55x DSPs and also as DLLs for Microsoft Windows
Mediatrix www.mediatrix.com	
Softphone	A PC-based VoIP communications application designed for use with standard analog telephone lines connected to the Internet • Uses SIP or MGCP to manage communications and RTP to transmit voice • Supports G.711, SIP RFC 2543 IP Telephony Protocol, and RTP-RFFC1889, RFC 1890 Real-Time Transport Protocols • Three GIPS SoundWare enhancements • Enhanced G.711 and IP-optimized codec compatible with G.711 • iPCM-wb, a wideband codec with high-fidelity sound • NetEQ combines adaptive jitter buffer and packet-loss concealment algorithms
Motorola www.motorola.com/computers	
PVRB672	Up to 882 full Voice over IP (VoIP) channels • High level software environment to reduce time-to-market and risk • Network options for DS/3, Gigabit Ethernet and PICMG 2.16 • Field proven voice processing resources including echo cancellation and tone generation/detection
WTRB500	A CompactPCI media processing blade • TMS320C6415 DSP array providing over 500 channels of AMR voice coding • High-performance PowerPC processor for control and management • Network interfaces for DS/3, Gigabit Ethernet, and PICMG 2.16 • Open telecom frame work soft are suitable for wireless transcoding, bulk call generator test equipment, video gateways, and server applications
Octasic www.octasic.com	
OCT9600 Series	A series of voice quality/echo cancellation modules • Performs high-quality echo cancellation and Voice Quality Enhancements (VQE) • Full complement of echo, tone, VQE, and ADPCM compression functions • Module is completely autonomous from host systems and is ready to operate immediately upon power up • Supports from 256 to 4032 voice channels in a single module • Support for customer-specific applications is delivered seamlessly via software updates
Performance Technologies www.pt.com	
MTN4100 PTMC Mezzanine Card	Complete VoIP processing solution • Industry standard PMC Module with PTMC pinout • Scalable from 12 to 120 ports in T1 and E1 increments • Universal port functionality • Field-hardened technology
Telco Systems www.telco.com	
EdgeGate CPE	A CPE VoIP gateway • Supports up to 4 analog voice lines and up to 8 10/100 Mbps Ethernet ports • Supports a variety of transmission technologies including 100 Mbps Ethernet, 100/1000 Mbps single-mode and multimode fiber optics, and VDSL • Supports full Layer 3 routing
Tundo Corporation www.tundo.com	
NTS Release 3.3	A Network Telephony System (NTS) • Tundo Distributed Open Telephony – Operating System (DOT-OS) provides real-time call processing features for endpoint devices • DOT-OS allows users to host voice services anywhere on their network, and configure N:M redundancy and automatic load balancing to achieve 99.999% availability on any scale • Tundo Media Framework (MFW) is an open, object-oriented application development environment that enables the rapid creation of innovative and reliable IP voice applications services independent of the changing IP telephony signaling and transmission standards • Tundo Media Server is a multi-point processor that supports conferencing and other services and can be deployed in scalable, fault tolerant configurations for non-stop performance • Provides G.711, G.729, G.723, and other transcoding functions for flexible voice and media support
Voiceboard www.voiceboard.com	
VS32-VoIP	The SuperSpan VS32-VoIP is a 60 port VoIP single board solution • A Dual software selectable T1/E1/J1 span configuration, dual 100Base-T connections, hot swappable, dual PTMC sites for optional DSP PMC and additional PowerPC 500 MIPS processor. High-density quad span provides 60-port channel capacity • Voice over IP (VoIP) software library is a set of downloadable modules for the SuperSpan VS32-VoIP MediaPro product. The VoIP library APIs support host application software access to a broad range of voice coding, VoIP and VoATM functionality • The VoIP software library includes G.726 ADPCM, G.729A/B CS-ACELP, G.723.1 and G.711 μ -a-law PCM vocoders, conversion of DTMF and Call Progress signals into IP data packets, G.168 Echo Cancellation, AGC, Comfort Noise Generation and Jitter buffering • Play/record of audio files, RTP packetization, 3 party conferencing for both IP and TDM network side parties
VS34-VoIP	The SuperSpan VS34-VoIP is a 120 port VoIP single board solution • A Quad software selectable T1/E1/J1 span configuration, dual 100Base-T connections, hot swappable, dual PTMC sites for optional DSP PMC and additional PowerPC 500 MIPS processor. High-density quad span provides 120-port channel capacity • Voice over IP (VoIP) software library is a set of downloadable modules for the SuperSpan VS34-VoIP MediaPro product. The VoIP library APIs support host application software access to a broad range of voice coding, VoIP and VoATM functionality • The VoIP software library includes G.726 ADPCM, G.729A/B CS-ACELP, G.723.1 and G.711 μ -a-law PCM vocoders, conversion of DTMF and Call Progress signals into IP data packets, G.168 Echo Cancellation, AGC, Comfort Noise Generation and Jitter buffering • Play/record of audio files, RTP packetization, 3 party conferencing for both IP and TDM network side parties
VoicePump www.voicepump.com	
VoicePump-6000	A software package for high-density, H.323-compliant VoIP gateways based on the TMS320C6000 family of fixed-point DSPs • Consists of DSP software that works in conjunction with a Windows host, providing a scalable, VoIP gateway • Capable of processing 24 full-duplex channels of fully compliant ITU-T G.729A on a single 200 MHz C6201 • Available for TI's C6201 Multichannel Evaluation Module PCI board • Easy migration path to TI's new Digital Thunder for VoDSL and other residential gateway applications

High Speed Networking Solutions

Performance, Reliability, Quality

Are you designing for network-enabled warfare? DDC offers ruggedized high speed networking boards in various form factors. Standard features include high performance hardware, extended temperature range, conduction cooling, dual redundancy, choice of fiber optic or copper interfaces, and a wide range of protocol and operating system support. Powered by DDC developed technology and intellectual property, our solutions continue to support the 20+ year life cycles of military and aerospace programs.

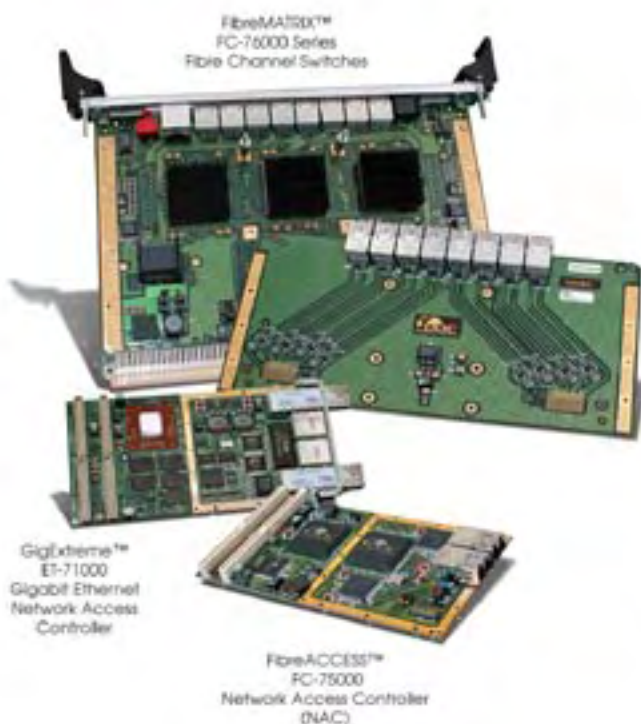

GigExtreme™ Network Access Controller

- Ruggedized, Conduction Cooled PMC Form Factor
- Auto-Negotiating 10/100/1000 Base-T or 1000 Base-SX Operation
- TCP/IP Offload Engine (TOE)
- Dual Independent Ports, or Autonomous Failover

FibreACCESS™ Network Access Controller

- Rugged, -40°C to +85°C Conduction Cooled PMC
- Fiber Optics or Copper Interface
- Dual Independent Ports, or Autonomous Failover

FibreMATRIX™ Switches

- Rugged, -40°C to +85°C Conduction Cooled
- 8- or 16-Port Switches
- Implicit & Explicit Login Support

Toll Free: 1-800-DDC-5757

Web: www.ddc-web.com

E-mail: info@ddc-web.com

Data Device Corporation
ISO 9001:2000 REGISTERED

RSC #61 @ www.embedded-computing.com/rsc

Embedded Computer Solutions For Harsh Environments

-40°C to +85°C Operating Temperature

Five Year Product Availability
Guarantee

ECM401

*World's Fastest
Embedded
Computer Module*

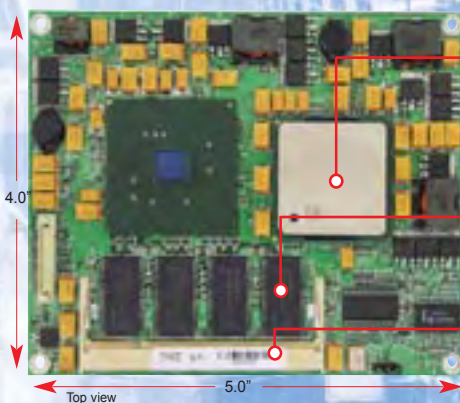

CPU, up to
2.8 GHz Pentium 4

(Low power 1.6Ghz and 2.0Ghz Pentium 4 also available)

512Mbytes soldered on-board
DDR memory expandable to
1.5Gbytes using SODIMM socket

SODIMM socket

Features:

- (6) Serial ports
- (4) USB 2.0 ports
- (1) 10/100Base-T
- Compact Flash Socket
- E-IDE supports 2 devices
- Video I/F (1600X1200, 32 Mb)
- AC'97 2.2 Audio
- Less than 5 seconds boot up time
- Intelligent thermal management with independent microcontroller
- **Power requirement:**
+12V @ 3A (2.0Ghz P4, 256MB)
- Over 200,000 hours MTBF

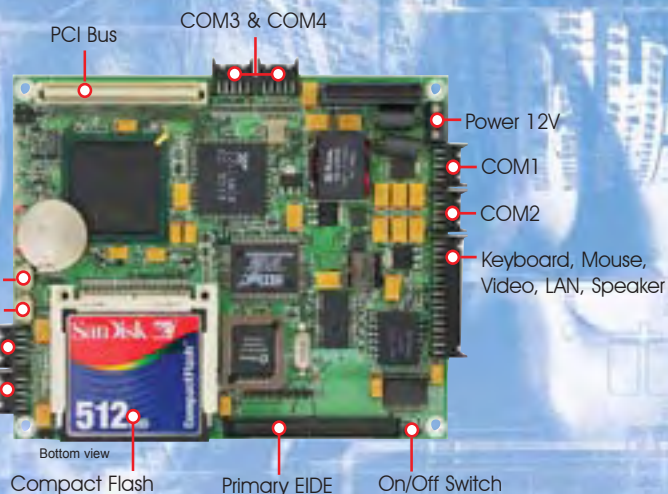

Over 10 years
in business of
designing and
manufacturing
embedded
computer
products for
OEMs and
System
Integrators

We can design your Embedded Computer Board in 30 days.

Time-to-market is very critical to a company's success.

TME has a proven development and manufacturing process that allows new embedded computer products, using TME's core technologies, to be developed in 30 days.

OEMs and System Integrators can now bring their products to the market without compromising cost and features at the expense of time.

Typical Applications

- | | |
|------------------|--------------------------|
| ▲ Robotic | ▲ Military/Aerospace |
| ▲ Medical | ▲ Industrial Automation |
| ▲ Avionics | ▲ Inventory management |
| ▲ e-Kiosks | ▲ Point Of Sale Terminal |
| ▲ Transportation | ▲ Test & Measurement |

ECM401 Embedded Computer Module provides all functions and features of a high performance computer on a very small Module.

Embedded Computer Designers can easily design an I/O board with proper connectors and form factor that is most suitable for their applications.

The ECM401 supports up to 1.5Gbytes DDR memory, 2.8GHz CPU, with built-in Audio, Video, USB, Network, serial, LPT interfaces and PCI BUS extension capability.



Toronto MicroElectronics Inc.

5149 Bradco Boulevard, Mississauga, ON., Canada L4W 2A6

Tel: (905) 625 - 3203 ~ Fax: (905) 625 - 3717

sales@tme-inc.com ~ www.tme-inc.com

By Chad Lumsden

BACKPLANE

ELMA Bustronic

Website: www.elmabustronic.com
Model: 7U ATCA Backplane **RSC No:** 19647
 Compliant to PICMG 3.0 Rev. 1.0 specification • Dual Star or Mesh configurations can be implemented • Gigabyte/Terabyte per second bandwidth per shelf • Connections to IPM Sentry shelf manager • 12 layer controlled impedance stripline design • 3X Replicated Mesh topology • Pluggable shelf manager option • Signal integrity characterization confirms high performance

ELMA Bustronic

Website: www.elmabustronic.com
Model: Low Profile Backplanes **RSC No:** 19649
 Conforms to PICMG basic specification 2.0 R3.0 • PICMG Hot Swap specification 2.1 R1.0 • Versions conforming to PICMG 2.16 are available • Versions conforming to PICMG 2.5 R1.0 for Computer Telephony are available • Designed to save a slot size of width, fit into low profile horizontal chassis • 8-layer and 10-layer controlled impedance stripline designs • Virtually zero crosstalk

BOARD ACCESSORIES

Keystone Electronic

Website: www.keyelco.com
Model: TO-3 Sockets **RSC No:** 19672
 A line of low-profile, TO-3 power transistor sockets, designed to facilitate installation of JEDEC-TO-3 MPM power transistors, by eliminating the need to use insulated bushings • Collector strip terminal with 6-20 formed threads at either end of the socket for mounting ease • Nylon tops accommodate .030", .045", .090" chassis thicknesses • Electro-plated spring brass contacts accept .040" and .060" pins • Phosphor bronze and beryllium copper contacts available by special order

CARD RACK ACCESSORIES

Mapsuka

Website: www.mapsuka.com.tw
Model: Card guide/Alum. extrusions **RSC No:** 19657
 A comprehensive list of card rack accessories, including card guides (160mm/80mm), EMC spring, tapped strip, insulating strip, handles for subrack and all sorts of aluminum extrusions • Custom lengths of cross rails, tapped strip, insulating strip, and EMC spring are available

DATACOM: SERIAL CONTROLLER

ACCES I/O

Website: www.accesio.com
Model: LPCI-COM-8SM **RSC No:** 19673
 An eight-port RS-232/422/485 serial communication card • Low-profile universal PCI form factor • Provides eight ports of field-selectable RS-232, RS-422, and RS-485 on a port-by-port basis • Includes a breakout cable with eight DB-9 connectors • Meets the MD2 low-profile PCI bus specification and can be installed in any 3.3 V or 5 V PCI or PCI-X slot • Includes type 16750 UART with 64-byte FIFO • Auto-RTS feature for

half-duplex RS-485 communications • Fixed bias and jumper-selectable termination on each transmit and receive channel • Speeds up to 921.6 K • Four-port and RS-232-only versions available



I/O: ANALOG

Acromag

Website: www.acromag.com
Model: IP231 **RSC No:** 19666
 An analog output IndustryPack mezzanine, each with its own high-resolution 16-bit D/A converter • Simultaneous D/A conversion across all channels enables the IP231 to write sixteen ±10 V outputs in 13 µs • Available in an eight-channel

model, and in optional extended-temperature versions for harsh environments • Software calibration maintains optimal accuracy using coefficients stored in EEPROM • Failsafe outputs reset to 0 V following a power up or reset • Software support for Windows, VxWorks, and QNX

Advantech

Website: www.advantech.com
Model: MIC-3714 **RSC No:** 19653
 3 FPM 2 TPC 12-bit A/D converter up to 30 MSps • 4 single-ended analog input channels • Programmable gain for each input channel • 32 K samples on board FIFO memory per channel • 4 A/D converters simultaneously sampling • Multiple A/D triggering modes • Programmable pacer/counter

QuickLogic

Website: www.quicklogic.com
Model: QL58x2 **RSC No:** 19644
 33/66 MHz 32-bit PCI Master/Target • Zero-wait state PCI Master provides up to 264 MBps transfer rates • Zero-wait-state PCI Target Write/One-wait-state PCI Target Read interface • Supports all PCI commands, including configuration and MWI • Supports fully-customizable byte enable for master channels • Target interface supports retry, disconnect with/without data transfer, and target

\$119

qty 100

- 200 MHz ARM
- 10/100 Ethernet
- PC/104 bus

TS-7200 ARM Single Board Computer



Shown with optional Compact Flash

- Boots Debian stable from Compact Flash
- Boots TS-Linux from on-board Flash
- Call for custom designs



\$149 qty 1

- 32 MB SDRAM (64 MB optional)
- 8 MB Flash (16 MB optional)
- Compact Flash
- 10/100 Ethernet
- 2 USB ports
- 20 Digital I/O
- 2 Serial Ports

Options:

- RS-485
- 8 ch 12-bit A/D
- USB WiFi

NEW

TS-7250 SBC \$149

32 MB Flash (128 MB Flash optional)



(480)-837-5200

www.embedded ARM.com

RSC #63 @ www.embedded-computing.com/rsc

about • Fully programmable back-end interface • Independent PCI bus (33/66 MHz) and local bus (up to 160 MHz) clocks • Fully customizable PCI Configuration Space • Configurable FIFOs with depths up to 256 words • Reference design with driver code (Win95/98/2000/NT 4.0) available • PCI v2.3 compliant • Supports Type 0 Configuration Cycles in Target mode • 3.3 V PCI signaling • 1.8 V supply voltage • 484-ball PBGA, 280-ball LFBGA, 208-pin PQFP, 196-ball TFBGA, and 144-pin TQFP packages • Supports Extendable PCI functionality • Unlimited/Continuous Burst Transfers supported

POWER SUPPLY

Technology Dynamics

Website: www.technologydynamicsinc.com
Model: HPRM Series **RSC No:** 19674
 A series of single/multiple output 10 KW rackmount

switching power supplies • Rugged construction meeting MIL-STD-80 • .92 power factor • EMI filtering to MIL-STD-461 • MS connectors input and output • Digital meters voltage and current • Circuit breaker input with trip guard • Overvoltage, overcurrent, and overtemperature protection • Remote inhibit and fault signals

PROCESSOR: PENTIUM MMX

Advantech

Website: www.advantech.com
Model: MIC-33513U **RSC No:** 19651
 4 ATM 3 FPM 2 TPC On-board Pentium MMX 266 CPU • Two SODIMM sockets support up to 256 MB SDRAM • On-board high-performance VGA display • On-board 10/100Base-TX fast Ethernet with RJ-45 connector • Supports 2 Ultra DMA/33 high-speed IDE devices • Accepts CompactFlash memory card • One PCI-to-PCI bridge drives up to

7 bus master peripherals • Compact 2-slot width • Supports on-board HDD, optional 1-slot wide mounting bracket for an onboard FDD

PROCESSOR: XEON

ADLINK Technology

Website: www.adlinktech.com
Model: ATCA-6890 **RSC No:** 19661
 Single/Dual Xeon processors with 800 MHz FSB • Dual channel DDRII-400 up to 16 GB • Two PMCs on private 64 bit 33/66/100/133 MHz PCI-X bus & One supports Jn4/Pn4 to RTM separately • 6 Gigabit Ethernet Data Ports: Four Fabric Interface and Two Base Interface • One 10/100/1000Mbit management port (front panel) • Two serial ATA ports • Optional on card mounted ATA hard drives • PICMG 3.1 compliant



RSC #19661

ROUTERS/SWITCHES

ADLINK Technology

Website: www.adlinktech.com
Model: ATCA-3100 **RSC No:** 19662
 PICMG 3.0 AdvancedTCA core specification • 1000Base-T Gigabit Ethernet • Layer 3 switching • Base interface support for 14 node slots • Full speed non-blocking switching (port to port) • One front panel GigE port (base interface access) • Support for ethernet shelf manager control (ShMC port)

ADLINK Technology

Website: www.adlinktech.com
Model: ATCA-3120 **RSC No:** 19663
 PICMG 3.0 AdvancedTCA core specification • 1000Base-T Gigabit Ethernet • Layer 3 switching • Base interface support for 14 node slots • Full speed non-blocking switching (port to port) • One front panel GigE port (base interface access) • Support for ethernet shelf manager control (ShMC port)

SOFTWARE: APPLICATION

UXComm

Website: www.uxcomm.com
Model: AutonomIQ **RSC No:** 19636
 Unified system management • Distributed element management • Modular architecture • Resource discovery • Event monitoring • Fault detection • Policy-based control

VIDEO: FRAME GRABBER

COGNEX

Website: www.cognex.com
Model: MVS-8501 **RSC No:** 19633
 Multiplexes up to four high-speed and standard analog cameras • Provides color graphics overlay for faster graphics processing • Allows fast and reliable image transfer through 32-bit/33 MHz bus architecture and 8MB FIFO • Provides the most reliable, accurate, and repeatable results through advanced Cognex software tools

Embedded Storage

We have a full range of embedded storage products and solutions. Think of ACT/Technico as your comprehensive *Storage Solution Provider.*



RAIDStor
- 2.16/31.1
- Hot Swap
- Removable
- Mirror/Stripe



PMCDisk



VME Disk Modules



Conduction Cooled PMcStor



PMcStor
Up to 8 GB on CFII

Features:

- ◆ **Drive types:** ATA/IDE, SATA, CompactFlash, Microdrives, SCSI, Solid State, DAT, floppy, CD-R/W, DVD-R/W. **Enhanced Duty, rugged and extended temperature versions available**
- ◆ **Platforms:** PowerPC/Pentium/SPARC on VME, VITA 31.1, cPCI and PMC
- ◆ **Operating Systems:** Linux, VxWorks, Windows and Solaris
- ◆ **Some models support enhanced shock specifications, ruggedization, and/or hot swap capability.**



www.acttechnico.com
Storage By Design

Sublets is a registered trademark of Sun Microsystems Inc.

RSC #64 @ www.embedded-computing.com/rsc

WE'VE LEFT THE COMPETITION BEHIND

AdvancedTCA[®] VENTUS ATCA 014 SHELF

By applying the use of existing technology in a unique way, APW Electronic Solutions' patented HSP Cooling Scheme gives the benefit of volume airflow with fault resilience. Both Computational Fluid Dynamics simulation and empirical airflow/thermal test data was used to optimize the design and validate the Shelf to meet NEBS and ETSI environmental requirements. The Shelf's distinctive angled front top edge and intake offer additional airflow margin when multiple Venti's are stacked in a cabinet.



FEATURES:

- *Lowest height (12U) in the industry with this much capability*
- *Redundant removable PEMs*
- *IPMI enabled FRUs*
- *Status LEDs in all FRUs*
- *Redundant Shelf Management Carriers*
- *HSP removable fan trays*
- *Fault tolerant cooling*
- *Cable management*

RSC #65 @ www.embedded-computing.com/rsc

ARCHITECTURES

ATCA | cPCI | VME | VME64X | VXI/PXI

For more information: sales.elsol@apw.com or visit www.apw.com/elsol

ADVERTISER INFORMATION

Page/RSC#	Advertiser/Product description	Page/RSC#	Advertiser/Product description
66	Abia Tech – Cube Systems & Low Power Solutions	21	JK Micro – PicoFlash
54	ACCES I/O – PC/104 Analog, Digital, Relay, and Serial I/O Boards	12	Kontron – ETXexpress-PM
1302	Acromag – IndustryPack I/O Modules	5	Micro/sys – EBX, EPIC, PC/104
15	Acromag – PMC I/O Modules	601	Opus Solutions – Smart Power Supplies
17	Acromag – PCI and CompactPCI I/O	29	Performance Tech – Advanced Managed Platforms
64	ACT/Technico – Embedded Storage	31	Performance Tech – Integrated Components
36	Advantech – Ruggedized PC Solutions	33	Performance Tech – Enabling Software & Middleware
49	American Arium – JTAG Emulation and Development Tools	9	Rabbit Semiconductor – Wireless Solutions for Embedded Control and Connectivity
68	American Portwell – Interactive Client Platform	44	Radian – PXH Thermal Solutions
65	APW – AdvancedTCA Ventus ATCA 014 Shelf	34	SBE – Linux On Demand
51	Arcom – XScale Based Single Board Computers	2	SBS – PMC/AdvancedMC
25	Artesyn – Telecom Infrastructure Applications	37	Sundance – SMT287, SMT290-VP7-5, SMT291
602	BMC – Universal Avionics Digital Interface	39	Sundance – SMT118, SMT148, SMT180
56	Bustronic – Test Accessories	41	Sundance – SMT6050, Diamond RT0S, GDD600 & GDD8000
46	Carlo Gavazzi – System Management	1301	TeamF1 – Security Protocol
61	Data Device – High Speed Networking Solutions	63	Technologic – ARM Single Board Computer
11	Diamond – Analog I/O PC/104 Board	52	Themis – Rugged Mission Critical Computers
23	Diversified Technology – Modular Platforms	38	Titan – Video, Imaging, and Graphics
7	Diversified Technology – Low Profile CompactPCI Platforms	62	Toronto Micro – ECM401 Embedded Computer Module
22	Elma – Embedded Packaging Solution	32	Toronto Micro – Embedded Computer Solutions
55	Embedded Planet – Embedded PowerPC/XScale	40	Toronto Micro – Embedded Computer
47	ICS – DaqPC Data Recorder	8	Tri-M – Hardware Solutions
45	Inova – Pentium M Celeron M	48	Tri-M – Engineered Solutions
27	Intel – Embedded Intel Architecture	67	Ultimate Solutions – LAN - Based JTAG Emulator
26	Interphase – Gigabit Ethernet products	18	Versallogic – Extended Life-Cycle Policy
42	Jacyl – Digital FPGA and Analog FPAAs PC/104 Boards	3	WinSystems – Embedded PCs

OpenSystems Publishing

Advertising/Business office:
30233 Jefferson Avenue
St. Clair Shores, MI 48082
Tel: 586-415-6500 ■ Fax: 586-415-4882

Vice President Marketing & Sales
Patrick Hopper
phopper@opensystems-publishing.com

Senior Account Manager
Dennis Doyle
ddoyle@opensystems-publishing.com

Account Manager
Tom Varcie
tvarcie@opensystems-publishing.com

Print and Online Marketing Specialist
Christine Long
clong@opensystems-publishing.com

Advertising/Marketing Coordinator
Andrea Stabile
astabile@opensystems-publishing.com

European Representative
Stefan Baginski
sbaginski@opensystems-publishing.com

Account Manager
Doug Cordier
dcordier@opensystems-publishing.com

Business Manager
Karen Layman

For reprints call the sales office: 586-415-6500

Cube Systems & Low Power Solutions!

FX5502

PII Grade compact system
(Celeron 400/650 Mhz)
w/VGA, 2S1P, 2 LAN, 2USB,
AUDIO, Compact Flash Drive
& DC Input



5.82"(D)x7.99"(W)x2.16"(H)



FB6500

Low Power 300Mhz,
VGA/LCD, Audio, LAN,
4 Serial Ports, USB & TTL I/O



FB2630

Intel ULV Celeron 400/650 Mhz
VGA, Audio, 2 LAN, 4 Serial Ports,
PC/104 Bus, mini-PCI Socket
5V only operation

Build a Solid state based Hard drive Quick & Easy!
Works with all different OS. No s/w drivers required!



FB4617

Bootable IDE Compact Flash Adapter
works with both 40/44 pins IDE bus.
Now supports Multi-DMA feature
for High Speed Transmission

*3.5" CF Disk Drive housing also available
info@abiatech.com



Abia Technology

tel: 714-821-8762

www.abiatech.com

RSC #66 @ www.embedded-computing.com/rsc

NOW AVAILABLE!

Embedded COMPUTING DESIGN

Digital Download

Now you can print and read *Embedded Computing Design* anytime, anywhere in the world.



www.embedded-computing.com/digital

Introducing The First LAN-Based JTAG Emulator for TI TMS320 DSPs!

The LAN560 JTAG Emulator is the first LAN-Based XDS560-class product offering by Blackhawk for debugging TI DSPs across a network.

- Supports TI DSP platforms: C6000, C5000, C2000, OMAP, VC33*
- Full compatibility with Code Composer Studio (CCS) IDE v2.20 and later and *Code Composer v4.1x for the VC33 in USB mode
- 10/100 Mbps Ethernet LAN interface
- High-speed USB2.0 (480 Mbits/sec) port
- Flexible 5 1/2 foot high-speed micro coax cable
- Auto-sensing low I/O voltage support
- Real-time non-intrusive Advanced Event Triggering capability
- Up to 100 times faster than XDS510 Emulators
- Windows® Plug n' Play Installaton



The Only Channel For Multiple Embedded Tools

www.ultsol.com

USI Tool Finder



Visit www.ultsol.com and use our unique Tool Finder to automatically and instantly discover the development tools for your particular platform.

Ultimate Solutions • 10 Clever Lane • Tewksbury, MA 01876-1580 • USA
Toll Free: 866.455.3383 • Fax: 978-926-3091 • Email: info@ultsol.com • Web: www.ultsol.com



PEB-7710VLA

embATX

EmbATX Industrial M/B, based on Intel® Pentium® 4 or Celeron® processor with DDR SDRAM, AGP 4X/VGA/EVD/S/DVI, Dual Display, Fast Ethernet and Audio

THINK Interactive Client, THINK American Portwell

Next Generation Interactive Client Platform => Dual Independent Display

▶ Maximum User's Image Experience

- ▣ Dual Independent Display
- ▣ Larger Display Like Plasma
- ▣ Dazzling Graphics And Audio
- ▣ Video on Demand
- ▣ Digital Broadcasting

▶ Minimum Waiting Time, Seamless Interaction

- ▣ Intel® Pentium® 4, Hyper Threading
- ▣ Intel® Low Power Pentium® M/Celeron® M
- ▣ Intel® Extreme Graphics 2, DDR SDRAM
- ▣ High Speed I/O, USB 2.0, POWER USB, IEEE1394
- ▣ Wire and Wireless Ethernet Connection



◀ ATM/Kiosk



◀ POS



◀ Gaming



◀ Medical

▶▶ Portwell Solution

PEB-3715VLA

5.25" ESB

5.25" ESB based on Intel® Pentium® 4 or Celeron® processor with DDR, AGP 4X VGA/Panel, Dual Display, Fast Ethernet and Audio



PEB-3730VLA

5.25" ESB

5.25" ESB based on Intel® Pentium® M or Celeron® M Processor with DDR SDRAM, AGP 4X, VGA/Panel, Dual Display, LAN and Audio



AREMO-7013

19" 2U Industrial rack-mount chassis for embedded M/B



PEC-5100

Chassis for 5.25" embedded board



RSC #68 @ www.embedded-computing.com/rsc



American Portwell Technology, Inc.

6851 Mowry Avenue Newark, CA 94560 USA

Tel: +1-510-790-9192 Fax: +1-510-790-9191

E-mail: info@mail.portwell.com

<http://www.portwell.com/embedded/>